

# STANZANI

Tools and equipment for body shops



clamps line



tools line



fast dent repair



glass line



garage line



## Catalogo generale General catalogue





# STANZANI

Tools and equipment for body shops

Siamo un'azienda specializzata nella progettazione, produzione e fornitura di accessori, strumenti e attrezzature professionali per autocarrozzerie o per la riparazione di lamierati in genere.

Attivi da oltre 40 anni, la nostra azienda si evidenzia per esperienza specifica, disponibilità di prodotti a magazzino e produzione di qualità, eseguita esclusivamente all'interno dello stabilimento, o con la collaborazione di abili tecnici artigiani del nostro territorio Emiliano Romagnolo (produzione esclusivamente italiana).

I nostri sistemi, in genere, si caratterizzano per la qualità dei materiali impiegati, per la semplicità d'uso da parte dell'operatore e, per alcune attrezzature, per l'esclusività del sistema applicato. La nostra gamma copre tutte le esigenze operative all'interno della moderna carrozzeria in termini di riparazione, con varie tecniche, di verniciatura, di tiro, movimentazione e stoccaggio.

I prodotti rappresentati nel catalogo possono subire modifiche tecniche ed estetiche nel tempo senza preavviso alcuno.

---

We are a company specialized in the design, manufacture and supply of professional accessories, tools and equipment for body shops or repair of sheet metal in general.

Active for over 40 years, our company stands out for specific experience, availability of products in stock and quality production, performed only inside the plant, or with the help of skilled technicians, craftsmen in our Emilia Romagna territory (Italian production only).

Generally speaking, our systems are characterized by the quality of materials employed, their user-friendliness and, as far as certain equipment is concerned, the exclusivity of the system applied. Our range covers all operational requirements within modern bodywork in terms of repair, using various techniques, painting, pull-clamps, handling and storage.

The products shown in the catalogue are subject to technical and aesthetic changes over time without prior notice.





## INDICE



### CLAMP LINE

pag. 5 - 41

Art. 80 - CAVO DI SICUREZZA | SAFETY CABLE  
 Art. 96 - STAFFA DI TIRO | PULL YOKE  
 Art. 121 - SKUBA  
 Art. 126 - PIKOLO  
 Art. 127 - SET DI TIRO PER SOSPENSIONI | MAC PHERSON  
 Art. 128 - AUTOBLOCK  
 Art. 130 - AUTOBLOK  
 Art. 131 - MORSETTO UNIVERSALE | UNIVERSAL PULL CLAMP  
 Art. 133 - MORSETTO A 90° | RIGHT ANGLE PULL CLAMP  
 Art. 134 - AUTOBLOK MAGNUM

Art. 135 - MORSETTO PLURIDIREZIONALE | SWIVEL PULL CLAMP  
 Art. 136 - RAPIDHOOK  
 Art. 137 - MORSETTO 75 | CLAMP 75  
 Art. 138 - BOOMERANG  
 Art. 139 - GRILLO  
 Art. 140 - PINZA  
 Art. 141 - Art. 142 - ARCO  
 Art. 141HD - Art. 142HD - ARCO  
 Art. 143 - PIASTRA MULTIUSO | MULTIPURPOSE PLATE  
 Art. 144 - TENAGLIA | PULL PLIER

Art. 144I - MORSA | HEAVY PULL PLIER  
 Art. 145 - MORSETTO PIATTO | FLAT CLAMP  
 Art. 146 - LUCCIO  
 Art. 147 - SLITTA - MORSETTO UNIVERSALE | SLITTA - SLIDE CLAMP  
 Art. 148 - MORSETTO 45 | PULL CLAMP 45  
 Art. 150 - MORSETTONE A "U" | LARGE "U" CLAMP  
 Art. 160 - KIT UNIVERSALE DI TIRO | UNIVERSAL PULLING SET  
 Art. 180 - MORSETTO DOPPIO | SIDE MEMBER CLAMP DOUBLE  
 Art. 181 - MORSETTO SEMPLICE | SIDE MEMBER CLAMP



### TOOLS LINE

pag. 43 - 108

Art. 55 - KIT CHIAVI | SOCKET WRENCH KIT  
 Art. 56 - MARTELLO PER CERNIERE | EXTRACTOR  
 Art. 57 - FERMAPORTIERE PER AUTOVETTURE | DOOR HOLDER  
 Art. 58 - SUPPORTO PORTELLONI | REAR DOOR HOLDER  
 Art. 90-95 - GANCI | HOOK  
 Art. 99 - RAGNO | SPIDER  
 Art. 100 - BLOK  
 Art. 102 - MONOBLOK  
 Art. 111 - TRAPEZIO  
 Art. 111S - TRAPEZIO  
 Art. 115 + Art. 103 - MAXICAR  
 Art. 116 + Art. 103S - SUV TROLLEY  
 Art. 117 - SVELTO  
 Art. 124 - ASSO  
 Art. 124V - TERENCE  
 Art. 125 - CAVALLETTI | PANEL REST  
 Art. 125E - Art. 125P - CAVALLETTI | PANELS REST  
 Art. 199 - VENTOSA

Art. 200 - KIT MARTELLO DI TIRO | SLIDE HAMMER SET  
 Art. 205 - MARTELLO DI TIRO HD | HD SLIDE HAMMER  
 Art. 206 - MARTELLO DI TIRO "THOR" | "THOR" SLIDE HAMMER  
 Art. 206/S - MARTELLO DI TIRO "THOR3" | "THOR3" SLIDE HAMMER  
 Art. 210 - KIT MARTELLO + GANCI DI TIRO | SET SLIDE HAMMER + HOOKS  
 Art. 215 - 219 - KIT MARTELLI IN ALLUMINIO | KIT ALUMINIUM HAMMERS  
 Art. 300 - PANNELLO ESPOSITORE A MURO | WALL TOOL PANEL  
 Art. 301 - ESPOSITORE A CARRELLO | TOOL TROLLEY  
 Art. 303R - NEW DISC DISPENSER  
 Art. 304 - CARRELLO PER LAMIERATI | STORAGE TROLLEY  
 Art. 305 - SGABELLO | STOOL  
 Art. 305A - PEDANA ALLUMINIO | ALUMINIUM LADDER  
 Art. 308 - Art. 308D - RASTRELLIERA PER PARAURTI | BUMPERS RACK  
 Art. 309 - ROTOFIX  
 Art. 309A - CARRELLO SALVASPAZIO | COMPACT TROLLEY

Art. 309C - RONNY  
 Art. 309V - CARRELLO PORTA-PARAURTI | BUMPER STAND  
 Art. 311 - PORTALIGHT  
 Art. 313 - RASTRELLIERA VERTICALE | VERTICAL RACK  
 Art. 317 - CART ROLLER  
 Art. 318 - CARRELLO ESTENSIBILE | TELESCOPIC TROLLEY  
 Art. 400 - METRO TELESCOPICO | TELESCOPIC TRAM GAUGE  
 Art. 570 - STRISCIA MAGNETICA | MAGNETIC STRIP  
 Art. 900 - KIT DI CINGHIE DI TIRO | PULL STRAP KIT  
 Art. 901 - FUNE DI TIRO | PULL RING  
 Art. 903 - TIRACINGHIE | SHACKLE  
 Art. 908 - KIT CINGHIE PER TIRO PESANTE | PULL STRAP KIT FOR HEAVY PULLING  
 Art. 1500-3000 - CATENE | CHAINS



### FAST DENT REPAIR

pag. 109 - 151

Art. 156A - MORSETTO RAPIDO IN ALLUMINIO | ALUMINIUM FAST CLAMP  
 Art. 157/Art. 159A - PIASTRINA ACCIAIO / PIASTRINA ALLUMINIO | WELD ON PLATES STEEL / ALUMINIUM  
 Art. 170 - ARTIGLIO  
 Art. 171 - MARTELLO DI TIRO LEGGERO | SLIDE HAMMER  
 Art. 171A - MARTELLO LEGGERO | LIGHT HAMMER  
 Art. 171D - MARTELLO CON PIASTRA | HAMMER WITH PLATE  
 Art. 171P - Art. 171Q - Art. 171R - Art. 177A - MARTELLO DI TIRO | SLIDE HAMMER  
 Art. 175 - Art. 175M - Art. 175V - POWER LIFT  
 Art. 179 - FALCON  
 Art. 179V - FALCON HAND PULLER  
 Art. 215 - KIT MARTELLO IN ALLUMINIO | KIT ALUMINIUM HAMMER  
 Art. 520 - Art. 523 - CARICATORE RONDELLE ASOLATE DIRITTE |

CHARGER FOR OVAL STRAIGHT WASHERS  
 Art. 524 - CARICATORE PULISCI RONDELLE | WASHER CLEANING CHARGER  
 Art. 560 - 560/S - 563 - SPEEDY P  
 Art. 580 - Art. 585 - Art. 587 - KIT COLLA | GLUE KIT  
 Art. 586 - KIT COLLA PROFESSIONALE | PROFESSIONAL GLUE KIT  
 Art. 660 - Art. 660B - Art. 661 - Art. 670 - CARRELLI | TROLLEY SPOT POWER  
 Art. 740 - MINI TRAVERSA | MINI DENT LIFTER  
 Art. 750 - TRAVERSA DI TIRO | PULL CROSSBAR  
 Art. 775 - X MONSTER  
 Art. 777 - MONSTER SYSTEM  
 Art. 610SG - SPOT POWER 230  
 Art. 630SG - SPOT POWER 400  
 Art. 640SG - ALU SPOT POWER

Art. 650SG - TWIN SPOTTER 230  
 Art. 810SG - KIT SPOT POWER STEEL  
 Art. 840SG - KIT SPOT POWER ALU  
 Art. 850 - CARRELLO | TROLLEY  
 Art. 855 - CARRELLO ECONOMY | ECONOMY TROLLEY  
 Art. 860 - CARRELLO ECONOMY | ECONOMY TROLLEY  
 Art. 870SG - TWIN WORK STATION  
 ACCESSORI PER ACCIAIO | STEEL ACCESSORIES  
 ACCESSORI PER ALLUMINIO | ALUMINIUM ACCESSORIES  
 CASSETTE CONSUMABILI PER SPOT POWER SYSTEM | CONSUMABLE BOXES TO SPOT POWER SYSTEM  
 CONSUMABILI PER SPOT POWER SYSTEM | CONSUMABLES TO SPOT POWER SYSTEM



### GLASS LINE

pag. 153 - 159

Art. 124V - TERENCE  
 Art. 313 - RASTRELLIERA VERTICALE | VERTICAL RACK

Art. 990 - WILLY  
 Art. 9930 - WILLY LIGHT



### GARAGE LINE

pag. 161 - 171

Art. 114T - MOTOGO TANDEM  
 Art. 305A - PEDANA ALLUMINIO | ALUMINIUM LADDER  
 Art. 311HT - HARD TOP  
 Art. 350 - CARRELLO VERNICIATURA SERBATOIO |

TANK COATING TROLLEY  
 Art. 353 - SUPPORTO VERNICIATURA CASCO | HELMET PAINTING HOLDER  
 Art. 450 - TYREGO

Art. 460 - DRILL BUMPER SENSOR  
 Art. 460L - 460M - DRILL BUMPER SENSOR  
 Art. 461 - SUPPORTO VERNICIATURA MAGNETICO | PAINTING MAGNETIC SUPPORT  
 Art. 463 - DOPPIA MORSA MAGNETICA | MAGNETIC DOUBLE CLAMP

CONDIZIONI GENERALI DI VENDITA | GENERAL TERMS OF SALE

pag. 174





# clamps line



Una linea completa morsetti di tiro indispensabili alle attività di carrozzeria, che agevolano il lavoro degli operatori. Prodotti utilizzati e collaudati da migliaia di professionisti della riparazione in ogni parte del mondo, costruiti con criteri orientati alla durata e alla semplicità di utilizzo.

---

A complete line of pull-clamps essential to bodywork activities, which facilitate the work of the operators. Products used and tested by thousands of repair professionals worldwide, built with durability and ease-of-use criteria.



## CAVO DI SICUREZZA | SAFETY CABLE Art. 80

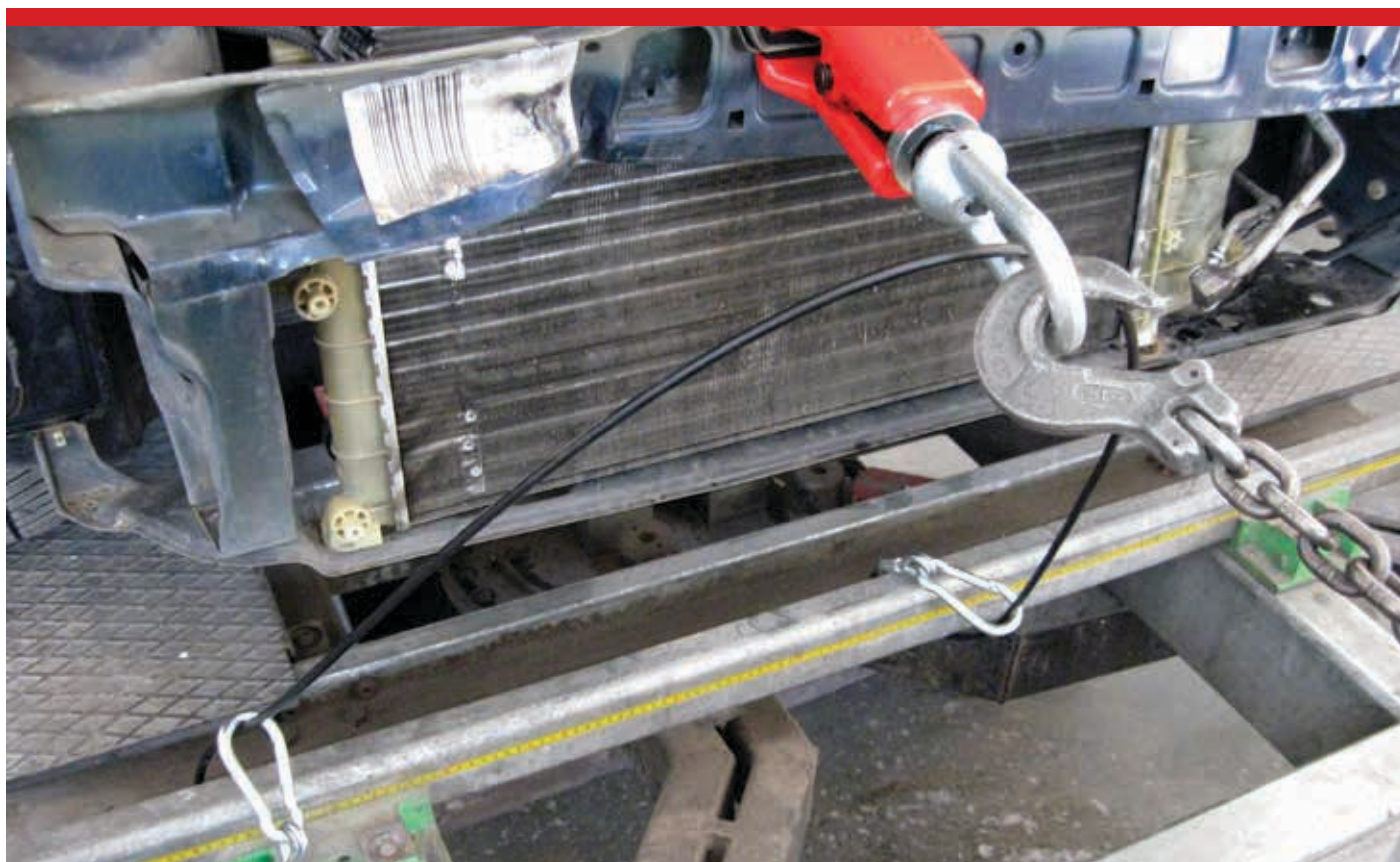

### Art. 80

Il cavo di sicurezza deve **SEMPRE** essere utilizzato, durante la fase di tiro, per fissare la catena + morsetto e/o gancio al lamierato.

In caso di distacco del pezzo di lamiera dalla carrozzeria, o di rottura della catena o di scivolamento del morsetto sulla lamiera, il cavo di sicurezza impedirà che questi materiali feriscano l'operatore. Per il suo corretto utilizzo, osservare i disegni indicati.

**IN CASO DI DANNI A PERSONE O COSE, CAUSATI DA MORSETTI, GANCI E CATENE DA NOI FORNITI, ED UTILIZZATI SENZA IL CAVO DI SICUREZZA, NON CI ASSUMEREMO ALCUNA RESPONSABILITÀ.**



The safety cable must **ALWAYS** be used during pulling to secure the chain + clamp and/or hook to the metal surface.

In the event of the metal coming away from the body, of the chain breaking or the clamp slipping on the metal surface, the safety cable will prevent the operator from being injured. For correct use, see the drawings indicated.

**WE DISCLAIM ALL LIABILITY IN CASE OF DAMAGE TO THINGS OR INJURY TO PERSONS CAUSED BY CLAMPS, HOOKS AND CHAINS SUPPLIED BY US, AND USED WITHOUT THE SAFETY CABLE.**

Caratteristiche tecniche Technical specifications		80
Materiale Row Material		acciaio con guaina in plastica steel with plastic sheath
Lunghezza Length	mm	2000
Peso, Weight	Kg	0,52

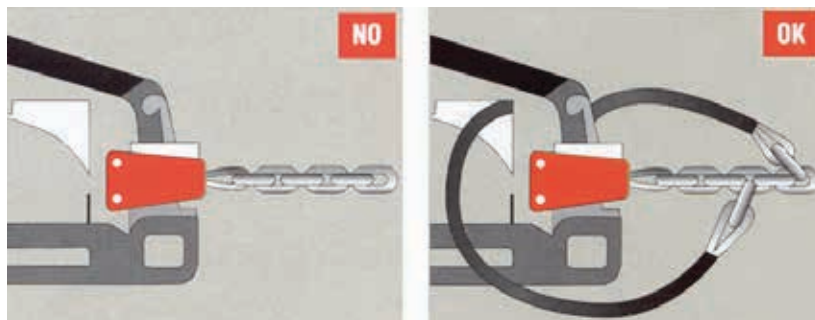





## STAFFA DI TIRO | PULL YOKE Art. 96



Art. 96 - Staffa di tiro  
Staffa di tiro da utilizzarsi da sola, o unitamente ai morsetti autobloccanti art. 131, 133, 137 e 148, qualora questi non siano dotati di anello o di golfare.  
I morsetti non sono compresi nella fornitura.

Pull yoke  
Pull yoke to be used alone, or in combination with self locking clamps item item 131, 133, 137 and 148, if they are not provided with pull ring or eye bolt.  
The clamps are not included in the delivery.

Caratteristiche tecniche Technical specifications		96
Materiale Material		acciaio zincato steel zink plated
Peso Weight	Kg	0,960

### Prodotti correlati | Related products

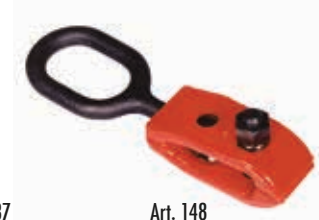



## SHARK Art. 120



Ganasce dentate  
intercambiabili  
Interchangeable jaws



### Art. 120

Il morsetto Shark è forgiato in acciaio. Il meccanismo di tiro del golfare permette di essere costantemente tenuto in posizione sia centrata, grazie alla apposita sede ricavata sulle due semi-pinze, che in posizione di sicurezza, impedendone la fuoriuscita. Il morsetto Shark è stato certificato per una portata di tiro di 6 Tonnellate.

Le ganasce in acciaio dentate, essendo temprate, sono di difficile usura. Sono tuttavia intercambiabili con relative ganasce di ricambio.

The Shark pull clamp is forged in steel. The eyebolt pulling mechanism allows it to be constantly kept in a centered position, thanks to the special seat obtained on the two semi-clamps, and in a safety position, preventing it from coming out.

The Shark pull clamp has been certified for a pulling capacity of 6 tons.

The toothed steel jaws, being hardened, are difficult to wear. However, they are interchangeable with relative replacement jaws.





## SHARK Art. 120

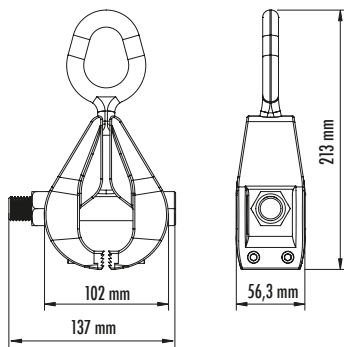

Caratteristiche tecniche Technical specifications		120
Materiale Raw Material		acciaio speciale special steel
Tenuta di tiro Pull strength	ton	6
Largezza ganasce Jaws width	mm	55
Peso Weight	Kg	7

## Prodotti correlati | Related products



Art. 3002S | Catene di tiro  
Pull chains



Art. 80 | Cavo di sicurezza  
Safety cable

Il cavo di sicurezza è fortemente raccomandato unitamente all'utilizzo di ogni tipo di morsetto e gancio di tiro

The use of the safety cable is strongly recommended together with all pull clamps and hooks



## SKUBA Art. 121



Ganasce dentate  
intercambiabili  
Interchangeable jaws



### Art. 121

Morsetto di tiro 55 mm autobloccante senza cerniere.

Il morsetto Skuba è autobloccante e non richiede il fissaggio mediante avvitamento sulla lamiera della carrozzeria. I morsettoni zigrinati, in acciaio antiusura temperato, sono intercambiabili.

Le cerniere di raccordo fra le due semipinze sono state sostituite da una robusta anella forgiata e tornita. Il meccanismo di autoblocco, costituito dal cono trapezoidale e dal perno filettato con relativa molla, è costantemente tenuto in centro dall' apposita sede ricavata sulle due semipinze, che ne impediscono la fuoriuscita.

Il Morsetto Skuba è forgiato in acciaio.

55 mm Self-Locking pull clamp without hinge.

The Skuba pull clamp is self-locking and does not need to be screwed onto the bodywork panel. The knurled jaws in hardened wear-resistant steel are interchangeable.

The connecting hinge between the two shells have been replaced by a tough, forged and turned ring. The self-locking mechanism, consisting of a trapezoid cone and of threaded pin with spring, is held constantly in the centre by the seat on the two shells which prevent it from escaping.

The Skuba pull clamp is forged from high strength steel.





## SKUBA Art. 121

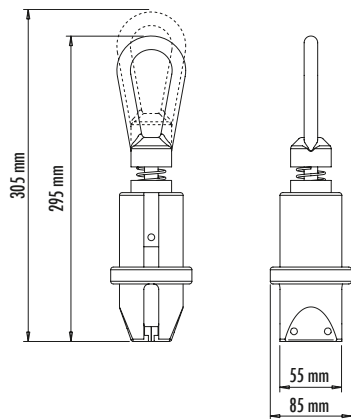

Caratteristiche tecniche Technical specifications		121
Materiale Raw Material		acciaio speciale special steel
Tenuta di tiro Pull strength	ton	6
Largezza ganasce Jaws width	mm	55
Peso Weight	Kg	3,2

## Prodotti correlati | Related products



Art. 90/91/92 | Ganci  
Hooks



Art. 80 | Cavo di sicurezza  
Safety cable

Il cavo di sicurezza è fortemente raccomandato unitamente all'utilizzo di ogni tipo di morsetto e gancio di tiro

The use of the safety cable is strongly recommended together with all pull clamps and hooks



Art. 3002S | Catene di tiro  
Pull chains



## PIKOLO Art. 126

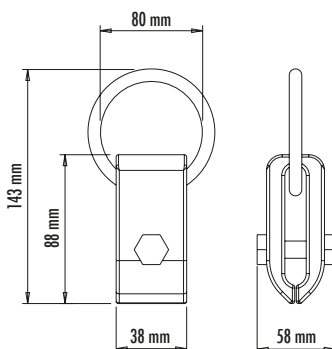

**Art. 126**  
Morsetto di tiro con fissaggio a vite, in acciaio ad elevata resistenza. Di piccole dimensioni, può essere facilmente applicato in qualsiasi posizione della carrozzeria.

Bolt-on-clamp in special steel high strength. Thanks to its small size, can be easily and safely applied onto any position of the car body.

Caratteristiche tecniche Technical specifications		126
Materiale Raw Material		acciaio steel
Tenuta di tiro Pull strength	ton	3
Peso Weight	Kg	0,800

### Prodotti correlati | Related products



Art. 3002S | Catene di tiro  
Pull chains



Art. 80 | Cavo di sicurezza  
Safety cable

Il cavo di sicurezza è fortemente raccomandato unitamente all'utilizzo di ogni tipo di morsetto e gancio di tiro.  
The use of the safety cable is strongly recommended together with all pull clamps and hooks.





## SET DI TIRO PER SOSPENSIONI | MAC PHERSON Art. 127

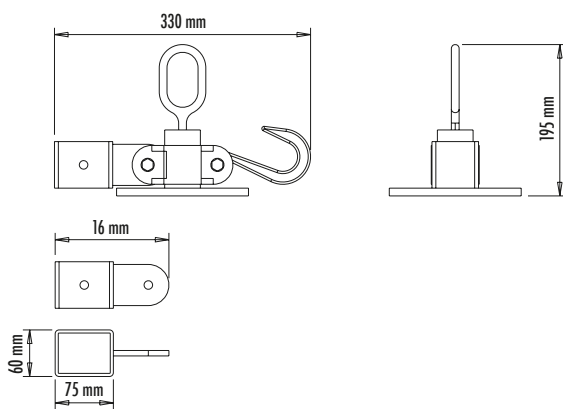

Art. 127

Set di tiro per sospensioni per vetture con sedi Mac Pherson dotate di fori.

Mac Pherson strut pulling kit, suitable for vehicles with holes on suspension location.

Caratteristiche tecniche Technical specifications		127
Materiale Row Material		acciaio steel
Portata di tiro Pull strength	ton	6
Peso Weight	Kg	4,5

### Prodotti correlati | Related products



Art. 160 | Kit universale per sospensioni per Mc Pherson  
Universal pulling set for Mc Pherson



Art. D0510200 | Braccio di tiro  
Pull Arm



## AUTOBLOCK 59 mm Art. 128

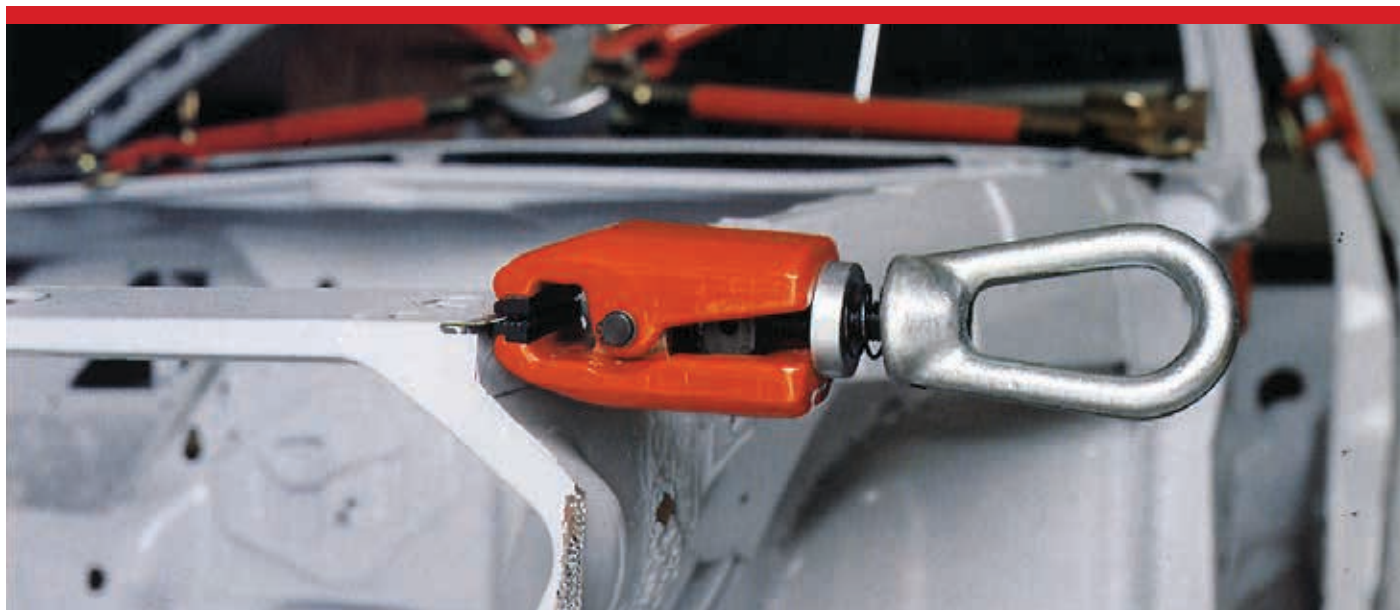

Ganasce dentate  
intercambiabili  
Interchangeable jaws

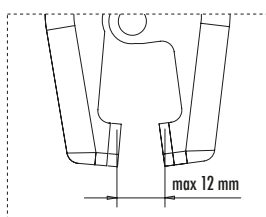
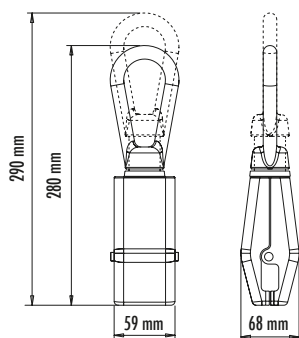

### Art. 128

Morsetti autoserrante da 6 ton. Morsetti autobloccanti a fissaggio rapido, mediante perno filettato fissato al golfare. Rimangono bloccati sul lamierato senza applicare forza di tiro. Ganasce dentate in acciaio speciale temperato antifusura. Larghezza ganasce 60 mm per tiri pesanti su parti di telaio, o in punti difficilmente accessibili.

Self-locking pull clamps 6 Ton. Self-locking pull clamps with fast fastening by means of threaded pin mounted to the pull ring. The Autoblock clamps remain locked on the metal panel without applying pull strength. Interchangeable jaws in special hardened steel for long life. Jaws width 60 mm for heavy pulls on frame parts.

Caratteristiche tecniche Technical specifications		128
Materiale Raw Material		acciaio speciale special steel
Tenuta di tiro Pull strength	ton	6
Larghezza ganasce Jaws width	mm	59
Peso Weight	Kg	3,5

## Prodotti correlati | Related products



Art. 3002S  
Catene di tiro  
Pull chains



Art. 80  
Cavo di sicurezza  
Safety cable

Il cavo di sicurezza è fortemente raccomandato unitamente all'utilizzo di ogni tipo di morsetto e gancio di tiro

The use of the safety cable is strongly recommended together with all pull clamps and hooks



## AUTOBLOCK 100 mm Art. 130



Ganasce dentate  
intercambiabili  
Interchangeable jaws

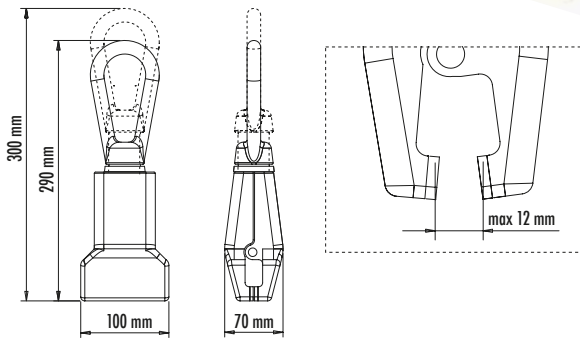

### Art. 130

Morsetti autoserrante da 10 ton. Morsetti autobloccanti a fissaggio rapido, mediante perno filettato fissato al golfare. Rimangono bloccati sul lamierato senza applicare forza di tiro. Ganasce dentate in acciaio speciale temperato antiusura.

Larghezza ganasce 100 mm per tiri su lamiere sottili.

Self-locking pull clamps 10 Ton. Self-locking pull clamps with fast fastening by means of threaded pin mounted to the pull ring. The Autoblock clamps remain locked on the metal panel without applying pull strength. Interchangeable jaws in special hardened steel for long life.

Jaws width 100 mm for heavy pulls on thin metal sheets.

Caratteristiche tecniche Technical specifications		130
Materiale Row Material		acciaio speciale special steel
Tenuta di tiro Pull strength	ton	10
Larghezza ganasce Jaws width	mm	100
Peso Weight	Kg	3,8

### Prodotti correlati | Related products



Art. 90/91/92 | Ganci  
Hooks



Art. 80 | Cavo di sicurezza  
Safety cable

Il cavo di sicurezza è fortemente raccomandato unitamente all'utilizzo di ogni tipo di morsetto e gancio di tiro

The use of the safety cable is strongly recommended together with all pull clamps and hooks





## MORSETTO UNIVERSALE | UNIVERSAL PULL CLAMP Art. 131

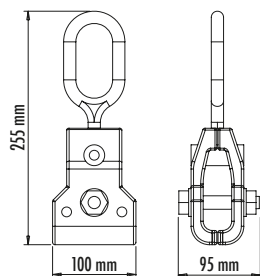

Ganasce dentate  
intercambiabili  
Interchangeable jaws

Art. 131  
Morsetto universale 100 mm. Ganasce dentate intercambiabili.

Universal pull clamp 100 mm. Interchangeable jaws.

Caratteristiche tecniche Technical specifications		131
Materiale Raw Material		acciaio steel
Tenuta di tiro Pull strength	ton	10
Larghezza Jaw width	mm	100
Peso Weight	kg	3,3

### Accessori | Accessories



Art. 119 | Anello di tiro  
Pull ring



Art. 96 | Staffa di tiro  
Pull yoke

Ambedue gli articoli possono essere utilizzati al posto del galfare di tiro  
Both references can be used in substitution of the pull eye



## MORSETTO A 90° | RIGHT ANGLE PULL CLAMP Art. 133



Ganasce dentate  
intercambiabili  
Interchangeable jaws

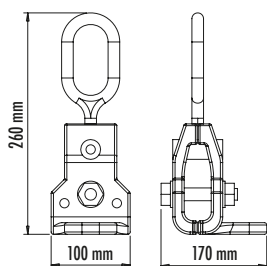

Art. 133

Morsetto ad angolo retto. Ganasce dentate intercambiabili.

Right angle pull clamp. Interchangeable jaws.

Caratteristiche tecniche Technical specifications		133
Materiale Row Material		acciaio steel
Tenuta di tiro Pull strength	ton	4
Larghezza Jaw width	mm	100
Peso Weight	kg	3,7

### Prodotti correlati | Related products



Art. 3002S | Catene di tiro  
Pull chains



Art. 80 | Cavo di sicurezza  
Safety cable

Il cavo di sicurezza è fortemente raccomandato unitamente all'utilizzo di ogni tipo di morsetto e gancio di tiro.  
The use of the safety cable is strongly recommended together with all pull clamps and hooks.



## AUTOBLOK MAGNUM Art. 134



Ganasce dentate  
intercambiabili  
Interchangeable jaws

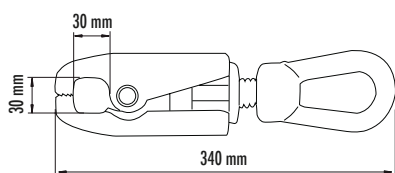

### Art. 134

Morsetto di tiro per impieghi pesanti.

Autoblock Magnum è un morsetto autobloccante, che non richiede il fissaggio mediante avvvitamento sulla lamiera della carrozzeria.

Magnum è dotato di una maggiore e più profonda apertura delle ganasce, per poter raggiungere anche punti più difficili.

Adatto per tiri fino a 10 Ton, è dotato di morsetti zigrinati intercambiabili.

### Heavy duty pull clamp

Autoblock Magnum is a selflocking pull clamp and eliminates the need to bolt on to the damaged panel before pulling.

Magnum is provided with a much wider and deeper jaw to get right into pulling area.

Suitable for pulls up 10 ton.

Caratteristiche tecniche Technical specifications		134
Materiale Raw Material		acciaio speciale special steel
Tenuta di tiro Pull strength	ton	10
Larghezza Jaw width	mm	60
Peso Weight	Kg	5

## Prodotti correlati | Related products



Art. 3001M | Catene di tiro  
Pull chains



Art. 80 | Cavo di sicurezza  
Safety cable

Il cavo di sicurezza è fortemente raccomandato unitamente all'utilizzo di ogni tipo di morsetto e gancio di tiro

The use of the safety cable is strongly recommended together with all pull clamps and hooks





## MORSETTO PLURIDIREZIONALE | SWIVEL PULL CLAMP Art. 135

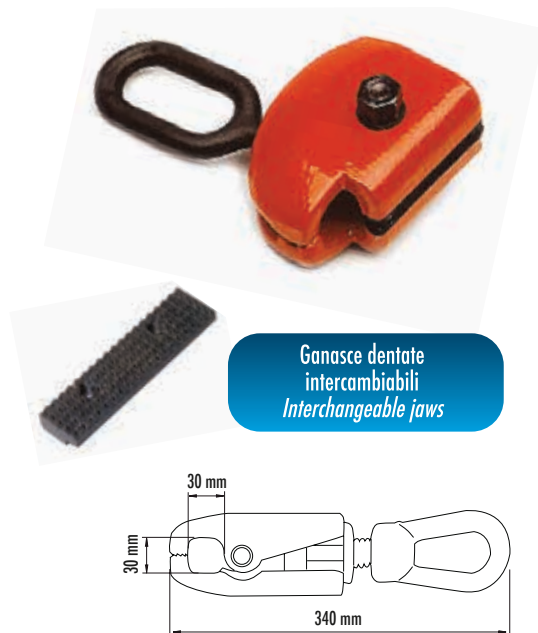

Art. 135  
Morsetto pluridirezionale - Ganasce dentate intercambiabili

Swivel clamp - Interchangeable jaws

Caratteristiche tecniche Technical specifications		135
Materiale Raw Material		acciaio speciale forgiato special forged steel
Tenuta di tiro Pull strength	ton	5
Larghezza Jaw width	mm	90
Peso Weight	Kg	3,8

### Prodotti correlati | Related products





## RAPIDHOOK Art. 136



Ganasce dentate  
intercambiabili  
*Interchangeable jaws*

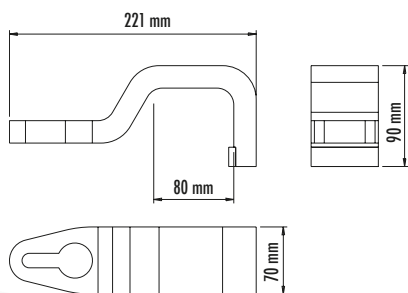

### Art. 136

Gancio di tiro rapido in acciaio ad elevata resistenza di ridotta dimensione. Può essere facilmente applicato in molte posizioni della carrozzeria.

High strength, small, steel rapid hook. Easy to apply to many positions on the body.

## Prodotti correlati | Related products



Art. 3002S | Catene di tiro  
Pull chains

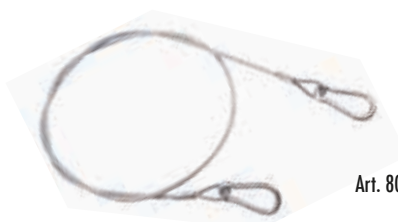

Art. 80 | Cavo di sicurezza  
Safety cable

Il cavo di sicurezza è fortemente raccomandato unitamente all'utilizzo di ogni tipo di morsetto e gancio di tiro.  
The use of the safety cable is strongly recommended together with all pull clamps and hooks.



## RAPIDHOOK Art. 136

### Applicazioni | Use mode



Caratteristiche tecniche Technical specifications		136
Materiale Row Material		acciaio steel
Tenuta di tiro Pull strength	ton	7
Peso Weight	Kg	2,1





## MORSETTO 75 mm | CLAMP 75 mm Art. 137

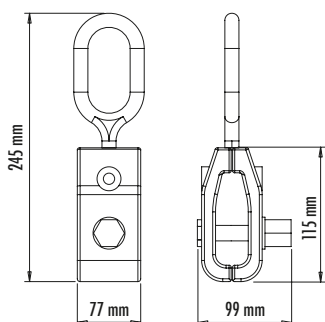
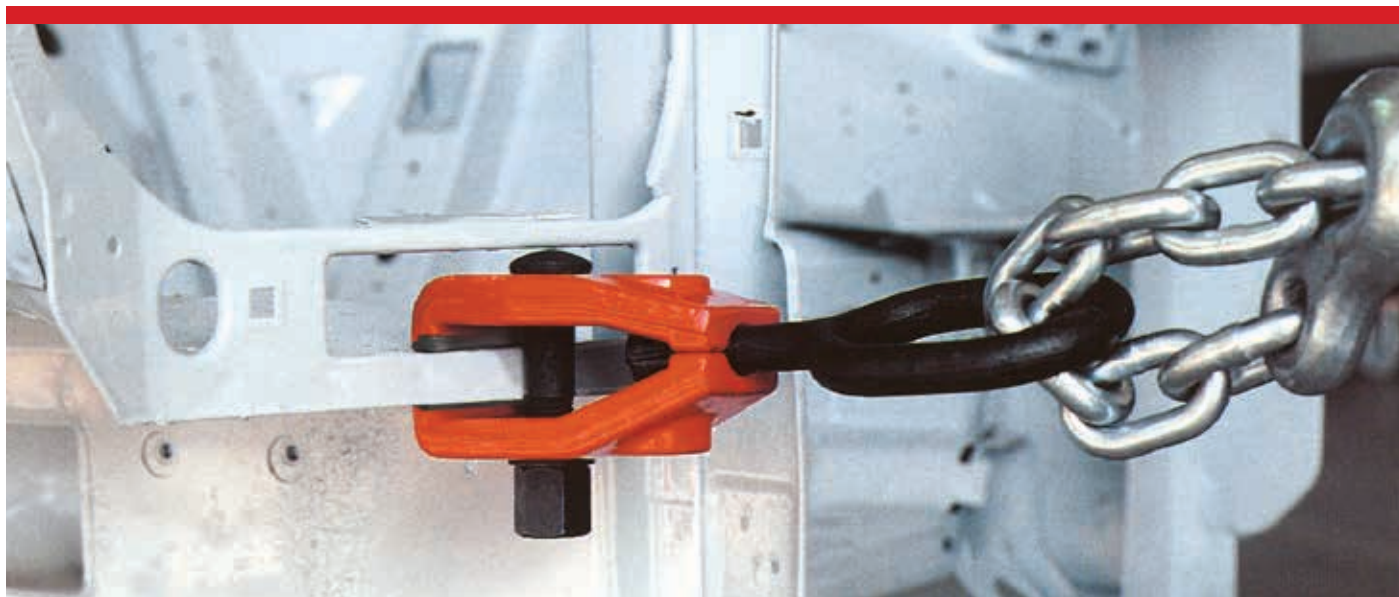

Ganasce dentate  
intercambiabili  
Interchangeable jaws

### Art. 137

Morsetto 75 mm con golfare.

La grande distanza delle due ganasce consente l'applicazione del Morsetto 75 al di sopra di lamiere dai bordi rialzati o particolarmente sporgenti.

Il particolare e unico dispositivo di serraggio (vite a testa quadrata in foro quadrato) consente di bloccare il controdado senza l'impiego della chiave inglese sulla testa della vite.

### Clamp 75 mm with eyebolt.

The large distance between the two shells enables the Clamp 75 to be used above panels with raised edges or large projections.

The unique tightening device (square-head screw in a square hole) allows the lock nut to be tightened without using a monkey wrench on the head of the screw.

Caratteristiche tecniche Technical specifications		137
Materiale Material		acciaio steel
Capacità di tiro Traction capacity	ton	6
Larghezza delle ganasce Jam width	mm	75
Peso Weight	Kg	2,8

## Applicazioni | Use mode





## BOOMERANG Art. 138



### Art. 138

Kit di tiro composto da un braccio ricurvo e kit accessori.

E' ideale per tiri pesanti su punti difficili da raggiungere della carrozzeria, ed elimina l'uso della catena e relative conseguenti "graffiature" della lamiera.

Costruito in acciaio stampato, riduce il rischio di eventuali rotture dovute ad eccessiva forza di tiro, garantendo la sicurezza dell'operatore.

Pull hook set complete with a body hook and a set of accessories.

It is ideal for pulling heavy and difficult to get at damaged areas whilst eliminating chain marking on the vehicle.

The Boomerang is manufactured with steel forged for increased safety, which reduces the break-risk in case of over-pulling.

Caratteristiche tecniche Technical specifications		138
Materiale Raw Material		Acciaio steel
Portata di tiro Pull strength	ton	6
Peso Weight	Kg	11

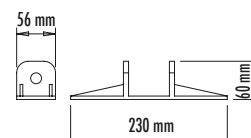
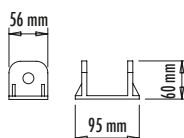
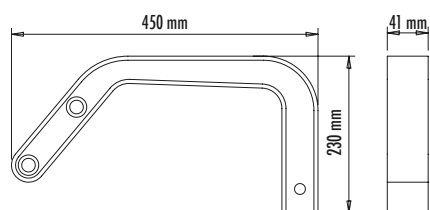



## GRILLO Art. 139



### Art. 139

Grillo - Morsetto 35 mm.

Morsetto per tiro a 90° forgiato. Grazie al golfare di rinvio avvitabile, il tiro può essere effettuato a 90° in due opposte direzioni, senza spostare il morsetto.

### Grillo - Pull clamp 35 mm.

Forged Midget clamp for 90° pull for easy and fast repair in no accessible positions. Thanks to the screw ring, the pull can be performed at 90° in two opposite direction, without removing the clamp from its positions.

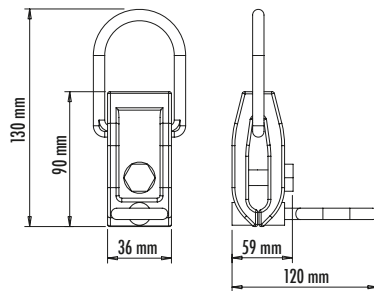

Caratteristiche tecniche Technical specifications		139
Materiale Raw Material		acciaio steel
Largezza ganasce Jaws width	mm	35
Tenuta di tiro Pull strength	ton	2
Peso Weight	Kg	0,800

## Prodotti correlati | Related products



Art. 140 | Pinza  
Pull clamp



Art. 145 | Morsetto piatto  
Flat clamp





## PINZA Art. 140

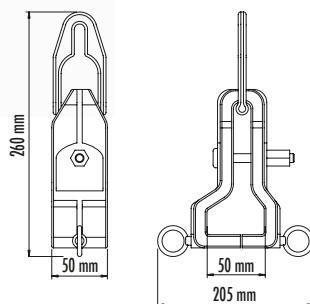

### Art. 140

Pinza - Morsetto per grondaie (profondità gola 50 mm).

Morsetto speciale per grondaie, con gola interna di 50 mm fornito completo di 2 anelli avvitabili per il tiro a 90°.

Grazie all'ampia gola può essere impiegato anche per oltrepassare zone di lamiera e/o telaio particolarmente ingombranti.

Pinza - Pull clamp with deep groove (50 mm).

Special pull clamp with internal groove 50 mm width, equipped with two screw rings for 90° pull.

Thank to its deep groove, this pull clamp is particularly suitable for pulls on thick frame parts.

Caratteristiche tecniche Technical specifications		140
Materiale Raw Material		acciaio steel
Tenuta di tiro Pull strength	ton	6
Larghezza delle ganasce Jaw width	mm	50
Peso Weight	kg	3,2

## Prodotti correlati | Related products



Art. 30025 | Catene di tiro  
Pull chains



Art. 80 | Cavo di sicurezza  
Safety cable

Il cavo di sicurezza è fortemente raccomandato unitamente all'utilizzo di ogni tipo di morsetto e gancio di tiro.

The use of the safety cable is strongly recommended together with all pull clamps and hooks.



## ARCO Art. 141 - Art. 142

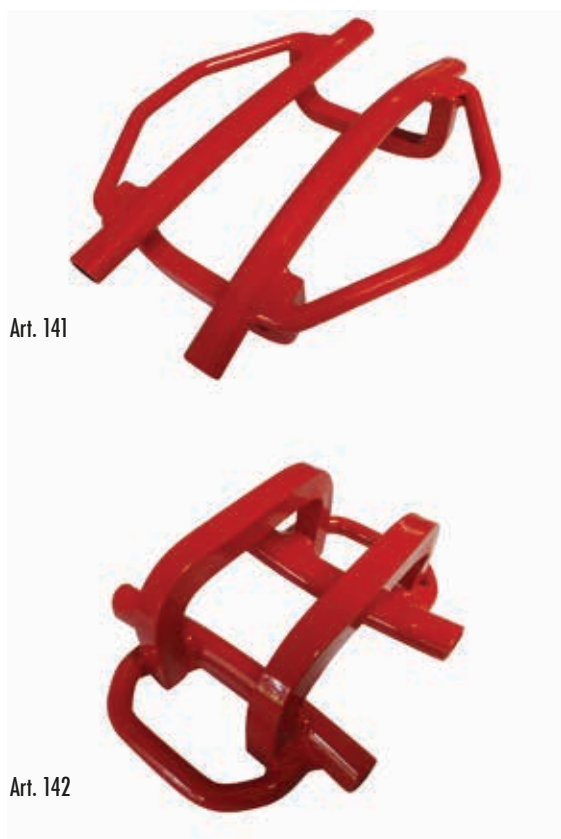

Art. 141

Art. 142

### Art. 141 - ARCO Grande

Adatto ai passaruota di tutte le autovetture, grazie alla doppia curvatura.

Max. capacità di tiro: 1500 kg

### Item 142 ARCO Piccolo

Utilizzabile anche per raddrizzare le aperture dei fanali e i supporti delle portiere.

Max. capacità di tiro: 1500 kg

### Art. 141 ARCO Large

The tools has two bendings, one on each side and will fit arches on almost all cars.

Max. capacity: 1500 Kg

### Item 142 ARCO Small

Same as the large model, but fits also light openings and door pillar.

Max capacity: 1500 kg

Caratteristiche tecniche Technical specifications		141	142
Materiale Raw Material			acciaio steel
Tenuta di tiro Pull strength	ton		2
Peso Weight	kg	2,4	1,6



## ARCO Art. 141HD - Art. 142HD



Art. 141HD - 142HD

Arco HD - Impiego pesante

Studiato per tutti i casi ove sia necessario applicare una forza di tiro elevata sul parafrangente. Pratico l'accorcia-catena incorporato.

Art. 141/HD per vetture con bordino da 22 a 24 mm

Art. 142/HD per vetture con bordino da 18 a 20 mm

Arco Heavy Duty

Suitable for all wheel arch repairs, that require a greater pulling strength.

With built-in chain shortener.

Item 141/HD for cars with wheel arch 22-24 mm

Item 142/HD for cars with wheel arch 18-20 mm



Art. 141/HD

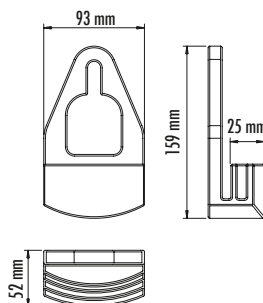

Art. 142/HD

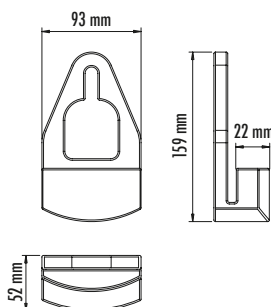

### Caratteristiche tecniche Technical specifications

	141HD - 142HD	
Materiale Raw Material		acciaio steel
Tenuta di tiro Pull strength	ton	7
Peso Weight	kg	1,5





## PIASTRA MULTIUSO | MULTIPURPOSE PLATE Art. 143

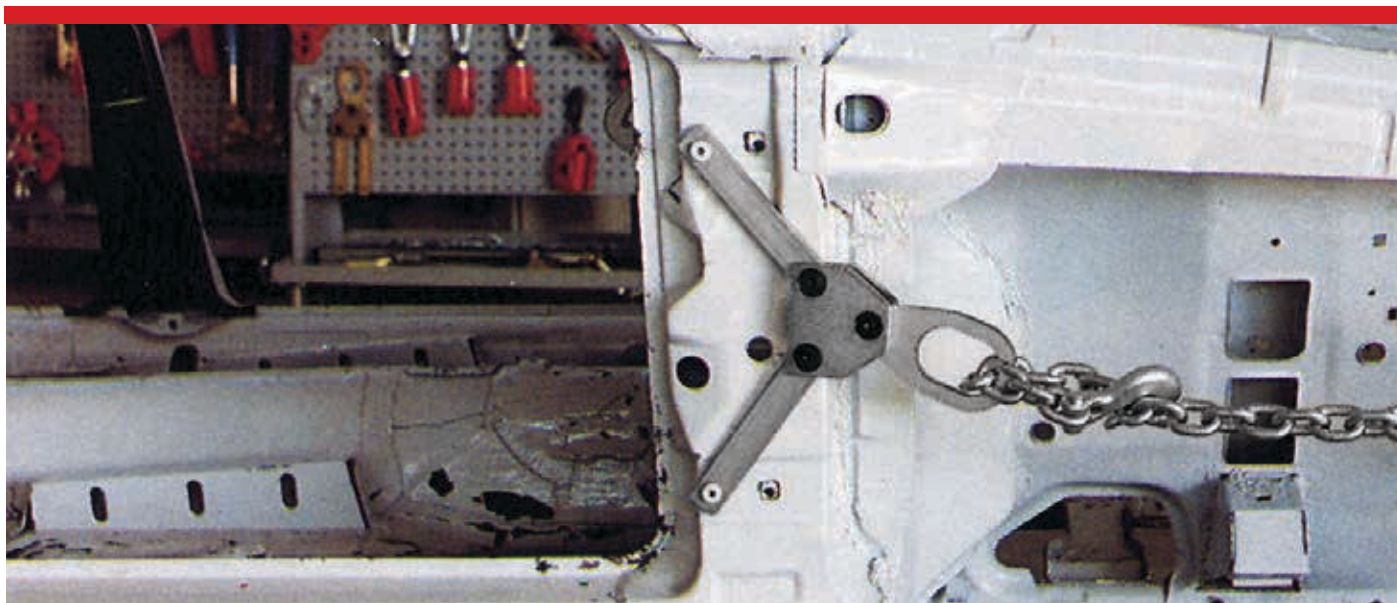

### Art. 143

Piastra di trazione. Grazie alla grande apertura dei due bracci (350 mm) il MULTIUSO consente di applicare una forza di tiro fino a 6 ton.

Può essere utilizzato anche su punti della carrozzeria non in linea fra di loro: ciò nonostante il tiro viene sviluppato sempre perpendicolarmente rispetto all'asse di applicazione

Traction plate. Thank to the wide opening of the arms articulated (350 mm), the MULTIPURPOSE makes it possible to apply a traction force of up to 6 ton on large metal surfaces or frames.

MULTIPURPOSE can be easily attached even to non - aligned points of the car body; in spite of this, the traction always extends perpendicular to the application line.

Caratteristiche tecniche Technical specifications		143
Materiale Row Material		acciaio zincato galvanized steel
Tenuta di tiro Pull strength	ton	6
Larghezza apertura bracci Arms aperture	mm	350
Lunghezza Lenght	mm	355
Peso Weight	Kg	2,7



## Prodotti correlati | Related products

Art. 123 | Piastra forata per trazione telaio  
Multi hole pull plate

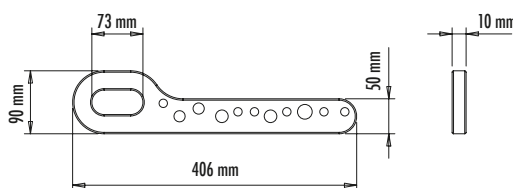



## TENAGLIA | PULL PLIER Art. 144

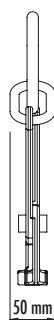
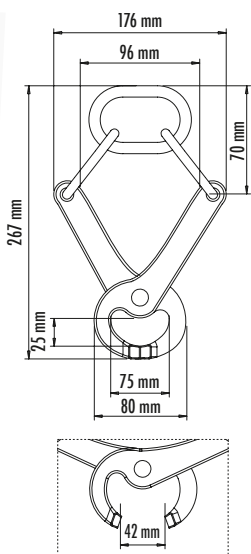
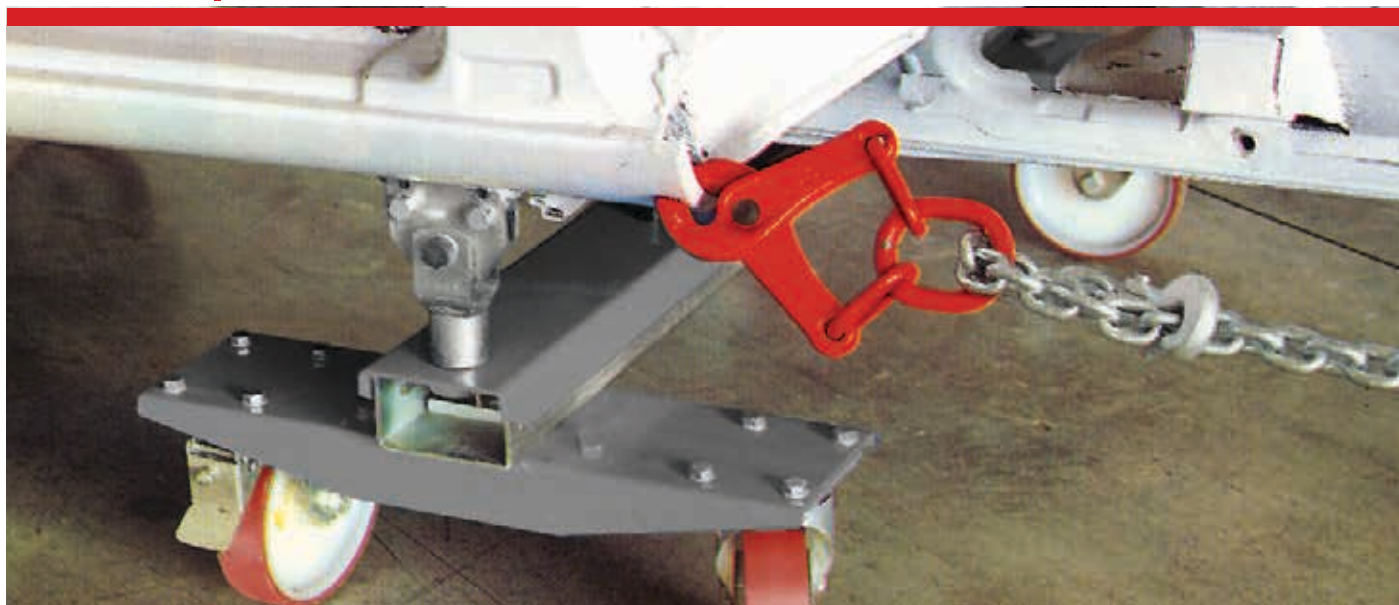

### Art. 144

Morsetto a tenaglia in acciaio forgiato. Le sue ridotte dimensioni e la grande apertura delle due semipinze lo rendono idoneo anche per le riparazioni in punti di difficile accesso.

La zigrinatura sulle due ganasce temperate è particolarmente "aggrappante", così da garantire una sicura presa sulla lamiera.

Pull pliers made of forged steel. Their compact size and wide opening make them suitable for use even in hard-to-reach spots.

The knurling on the two tempered jaws ensures a sturdy grip.

Caratteristiche tecniche Technical specifications		144
Materiale Raw Material		acciaio steel
Tenuta di tiro Pull strength	ton	4
Peso, Weight	Kg	3,2

## Prodotti correlati | Related products



Art. 3002S | Catene di tiro  
Pull chains



Art. 80 | Cavo di sicurezza  
Safety cable

Il cavo di sicurezza è fortemente raccomandato unitamente all'utilizzo di ogni tipo di morsetto e gancio di tiro. The use of the safety cable is strongly recommended together with all pull clamps and hooks.





## MORSA | HEAVY PULL PLIER Art. 144I

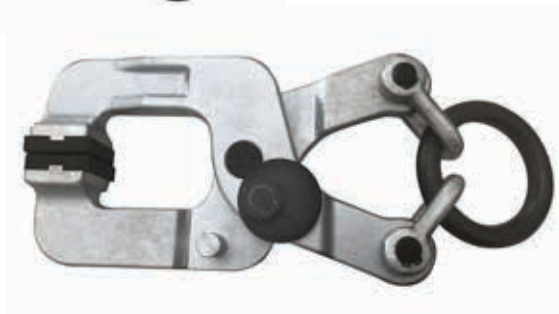

Art. 144I  
Morsa.

La particolare conformazione delle due semipinze, unitamente all'ampia gola, rendono questo utensile idoneo soprattutto per riparazioni in punti di difficile accesso.

La speciale lega di acciaio utilizzata per la costruzione, ed il design molto robusto permettono di applicare a questa tenaglia una forza di tiro fino ad un massimo di 8 ton., senza che intervengano deformazioni o rotture dell'utensile. La "MORSA" è quindi idonea per la raddrizzatura di parti di telaio pesantemente danneggiate, che richiedano una grande potenza di tiro.

### Heavy Pull Plier.

The particular shape of the two half-grippers, together with the wide neck, make this tool particularly suitable for repairs in positions where access is limited.

The special steel alloy used and the sturdy design allow a maximum pull force of 8 ton to be applied to the tool without causing breaking or buckling. The MORSA is therefore ideal for straightening severely damage parts of the chassis which require considerable pull force.





## MORSA | HEAVY PULL PLIER Art. 144I

### Dettagli | Details



Il dispositivo di bloccaggio ad eccentrico permette di fissare la "MORSA" sulla carrozzeria, senza doverla sottoporre a tiro. È quindi sufficiente un solo operatore, con conseguente risparmio di tempo.

The eccentric locking device allows the "MORSA" to be fixed to the bodywork without the need to apply pull force. As a result just one operator is required, making for valuable time savings. The knurled clamp sections are in hardened steel for greater wear resistance.

Caratteristiche tecniche Technical specifications		144I
Materiale Row Material		acciaio in lega speciale indeformabile - zincato special steel indeformable zinkplated
Tenuta di tiro Pull strength	ton	8
Peso Weight	Kg	5,2

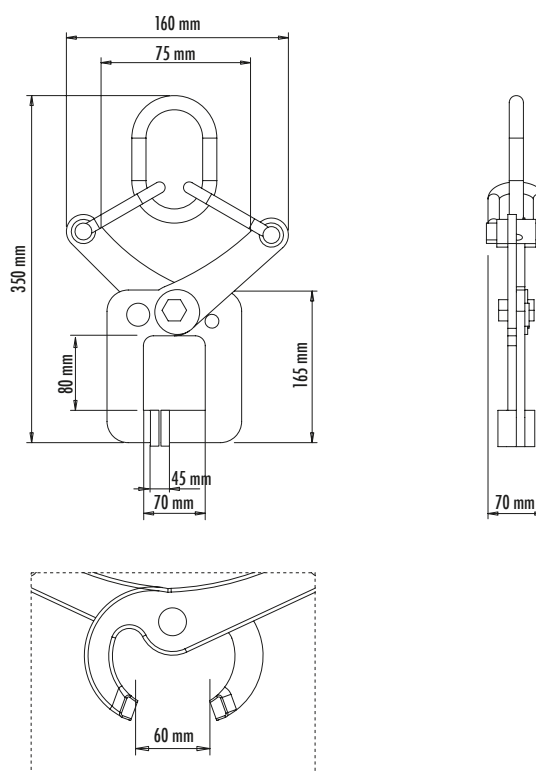

### Prodotti correlati | Related products



Art. 30025 | Catene di tiro  
Pull chains



Art. 144 | Tenaglia  
Clamp



## MORSETTO PIATTO | FLAT CLAMP Art. 145



### Art. 145

#### Morsetto Piatto.

Morsetto ultrapiatto adatto per posizioni su scatolati, ove gli ingombri delle lamiere non consentano l'accesso a morsetti di normale spessore (ad esempio l'interno di longheroni laterali).

Il morsetto piatto è dotato di alcune importanti caratteristiche costruttive:

L'anello di rinvio a 90° smontabile, consente di modificare la direzione del tiro, senza smontare il morsetto dalla posizione iniziale.

Il golfare funge da accorcias catena e contemporaneamente da cuneo, sviluppando un'azione "auto serrante" delle due ganasce anteriori durante il tiro.

Il particolare dispositivo di serraggio, mediante vite a testa quadrata in foro quadrato, consente di bloccare il controdado senza l'impiego di una seconda chiave inglese sulla testa della vite, con risparmio di tempo e maggiore facilità di utilizzo.

#### Flat clamp.

Extra-flat clamp especially suited for boxed - in positions, where the clutter of assembled parts does not allow access by normal-sized clamps (for example, inside the side frames).

The flat clamp is fitted with a number of important features:

The 90° transmission ring, removable, makes it possible to change the pulling direction without detaching the clamp from its original positions. The eyebolt acts as a chain shortener, making the flat clamp faster and easier to use.

The thickness of the eyebolt acts a wedge, creating a "self-locking" effect on the two front jaws while pulling. The unique tightening device (square-head screw in a square hole) allows the lock nut to be tightened without using a monkey wrench on the head of the screw, making for time savings and greater simplicity of use.

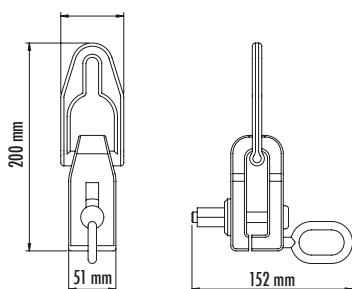

Caratteristiche tecniche Technical specifications		145
Materiale Row Material		acciaio steel
Tenuta di tiro Pull strength	ton	3
Larghezza delle ganasce Jaw width	mm	51
Peso Weight	kg	1,8



## LUCCIO Art. 146

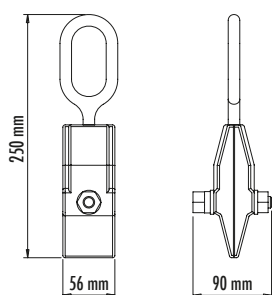

### Art. 146

#### Morsetto - Luccio.

La parte anteriore di questo morsetto è molto piatta e sottile, pur garantendo una solida presa grazie alla robusta zigrinatura.

E' adatto per l'applicazione in strette fessure o posizioni difficilmente accessibili. Il fermo per la testa della vite sulla semipinza ne consente il serraggio senza l'impiego di una seconda chiave inglese, con conseguente risparmio di tempo e maggiore facilità di utilizzo.

### Clamp - Luccio.

The front part of this pull clamp is very flat and thin, yet it provides a tight hold on metal panels thanks to the gripping teeth.

It suits very narrow openings and inaccessible positions on bodywork. The special design of on clamp shell allows the lock nut to be tightened without using a monkey wrench on the head of the screw, making for time savings and simplicity of use.

Caratteristiche tecniche Technical specifications		146
Materiale Raw Material		acciaio steel
Tenuta di tiro Pull strength	ton	4
Larghezza delle ganasce Jaw width	mm	56
Peso Weight	kg	1,8

## Prodotti correlati | Related products



Art. 3002S | Catene di tiro  
Pull chains



Art. 80 | Cavo di sicurezza  
Safety cable

Il cavo di sicurezza è fortemente raccomandato unitamente all'utilizzo di ogni tipo di morsetto e gancio di tiro. The use of the safety cable is strongly recommended together with all pull clamps and hooks.



## SLITTA - MORSETTO UNIVERSALE | SLITTA - SLIDE CLAMP Art. 147

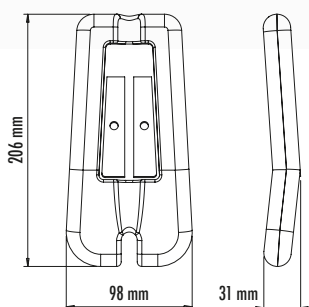
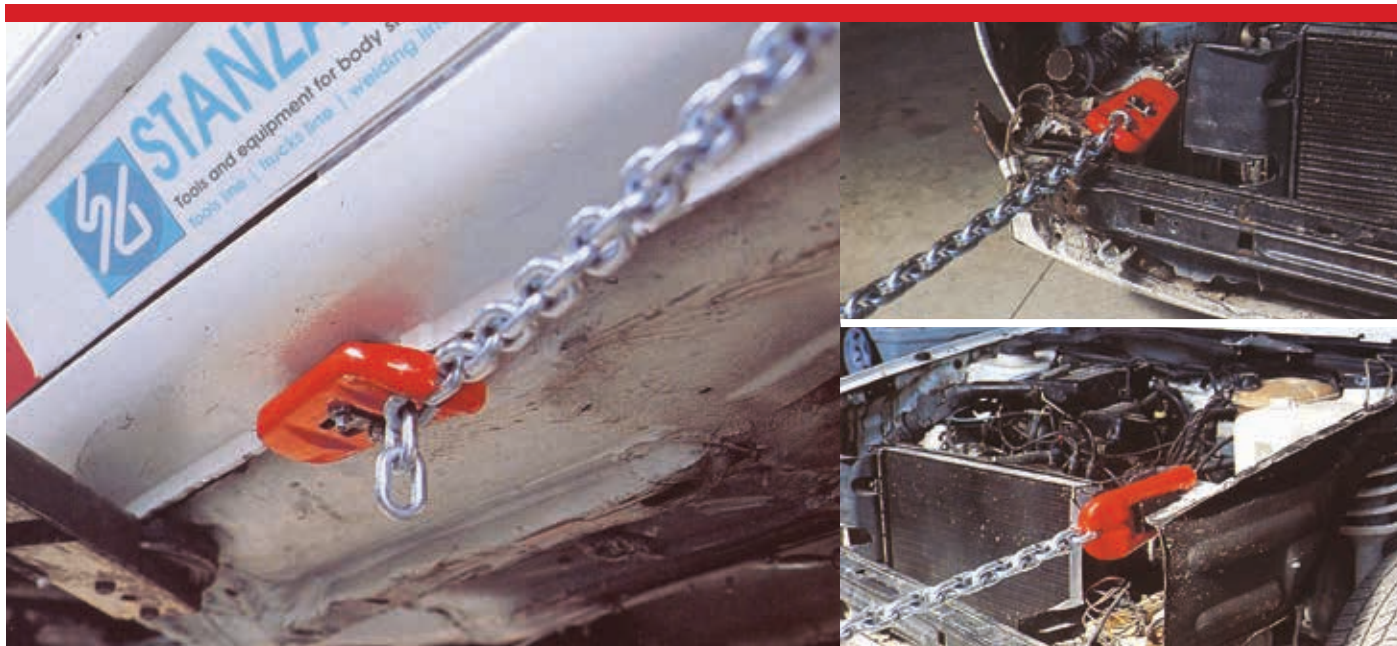

### Art. 147

Slitta - Morsetto orizzontale. Indispensabile per tiri paralleli orizzontali su tutti i bordini delle lamiere. Dotato di 2 morsetti molto grippanti, montati a cuneo, che si bloccano automaticamente sul bordino al momento del tiro. Può essere smontato molto velocemente con un semplice colpo di martello.

### Slitta - Slide clamp

Indispensable clamp for horizontal pulls. It is equipped with 2 gripping jaws, assembled as a wedge, that automatically lock on the sill panel during pulling. It can be quickly applied and removed with a hammer blow.

Caratteristiche tecniche Technical specifications		147
Materiale corpo Material clamp		ghisa sferoidale cast iron
Capacità di tiro Traction capacity	ton	8
Morsetтини Jaws		acciaio speciale temperato special treated steel
Peso Weight	kg	2,7

### Accessori | Accessories



Art. 904 Grillino  
Shackle



Art. 135 Morsetto pluridirezionale  
Swivel clamp



Art. 123 Piastra forata per  
trazione telaio  
Multi hole pull plate



Art. 80 Cavo di sicurezza  
Safety cable

Il cavo di sicurezza è fortemente raccomandato unitamente all'utilizzo di ogni tipo di morsetto e gancio di tiro. The use of the safety cable is strongly recommended together with all pull clamps and hooks.



## MORSETTO 45 mm | PULL CLAMP 45 mm Art. 148

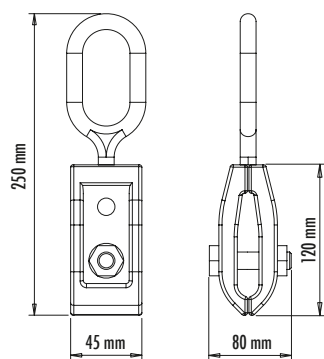

### Art. 148

Morsetto universale da 45 mm con serraggio manuale a vite e bullone. Adatto per tutti i tiri su carrozzerie di autoveicoli. A scelta disponibile sia con anello di tiro che con golfare.

Universal clamp 45 mm with manual locking by means of screw and nut. Suitable for all kinds of pulls on car bodies. Available with pull ring or pull eye.

Caratteristiche tecniche Technical specifications		148
Materiale Row Material		acciaio steel
Largezza ganasce Jaws width	mm	45
Tenuta di tiro Pull strength	ton	4
Peso Weight	Kg	1,8

## Accessori | Accessories



Art. 119 | Anello di tiro  
Pull ring





## MORSETTONE A "U" | LARGE "U" PULL CLAMP Art. 150

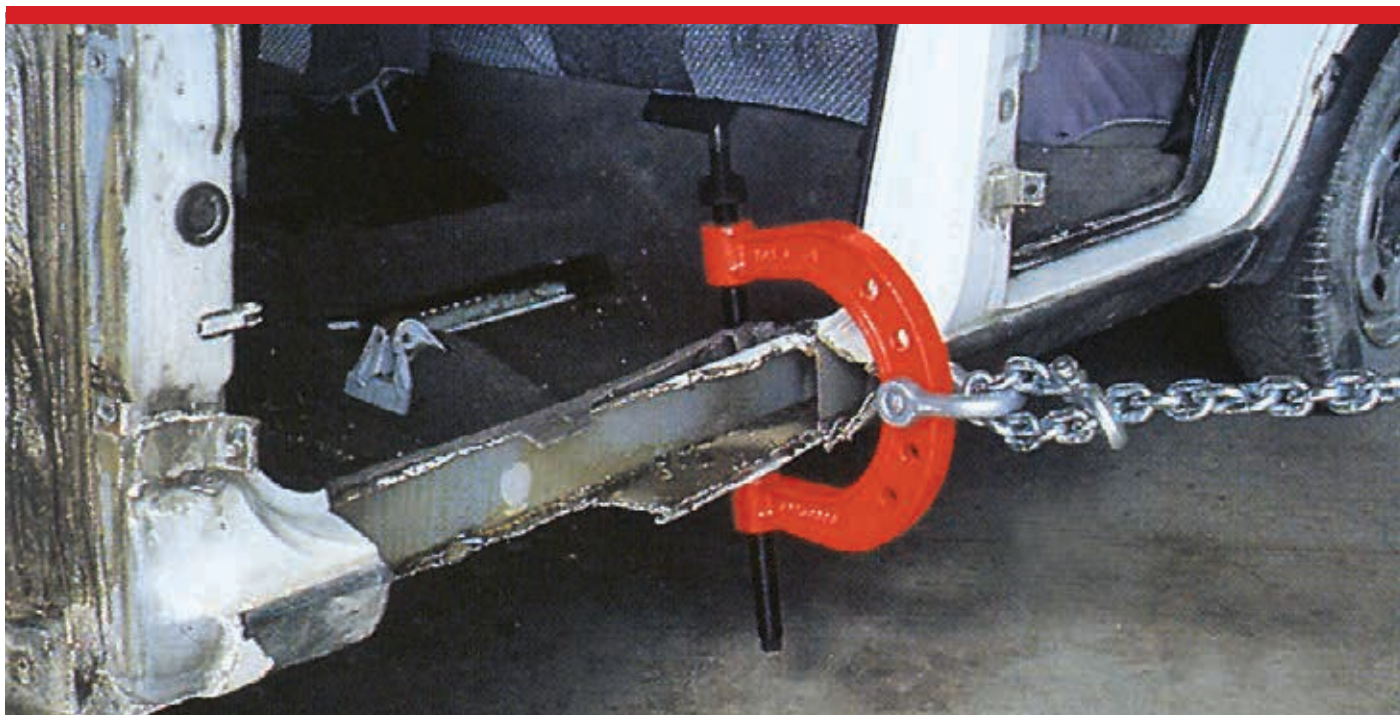

Art. 150

Morsettone a U.

La grande apertura e la profonda gola interna lo rendono specificatamente idoneo per l'applicazione su lamierati pesantemente accidentati, e quindi voluminosi.

Ambedue le viti possono essere svitate completamente per ottenere la massima apertura di accesso. I morsetti zigrinati sono orientabili, per la max. flessibilità di utilizzo. I fori sulla mezzaluna consentono diverse angolazioni di tiro.

Large U pull clamp.

The great opening and very deep reach make this clamp suitable for use on heavily damaged vehicles.

Both screw can be completely pulled back, so to obtain maximum opening. The strong gripping jaws can be rotated and adjusted to suit any pulling position. The holes on the semicircle allow for different pull angles.



### Prodotti correlati | Related products



Art. 904 Grillino Shackle



Art. 1502S Catene di tiro Pull chains





## MORSETTONE A "U" | LARGE "U" PULL CLAMP Art. 150

### Applicazioni | Use mode



Caratteristiche tecniche Technical specifications		150
Materiale Raw Material		ghisa sferoidale/morettini acciaio temperato clamp spheroid cast iron/Jaws special hardened steel
Max capacità di tiro sulla vite Pullout strength on the screw eye bolt	ton	4
Max capacità tiro su mezzaluna Max pullout strength on semicircle	ton	8
Peso, Weight	kg	7,5

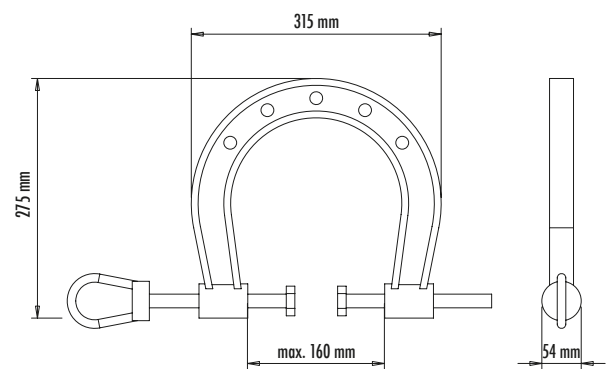

Ganasce dentate  
intercambiabili  
Interchangeable jaws



## KIT UNIVERSALE DI TIRO | UNIVERSAL PULLING SET Art. 160



### Art. 160

Kit universale di tiro MC PHERSON.

Kit universale per sospensioni. Grazie ai dischi di vari diametri, questo utensile consente il ripristino preciso della sede delle sospensioni a forma circolare.

L'applicazione del tiro all'altezza della sede dell'ammortizzatore evita di lavorare fuori asse. Possibilità di tiri orizzontali in tutte le direzioni richieste. Possibilità di tiro verticale a tiro orizzontale, senza spostare l'attrezzo. Di robusta e compatta costruzione, è universalmente utilizzabile su tutti i veicoli con sedi sospensioni a forma circolare.

BRACCIO DI TIRO NON COMPRESO.



Universal pulling set for MC PHERARSON strut.

Thanks to the discs of different diameter, this tool precisely restores the suspension housing to its round shape.

Fitting for pull at shock absorber height, avoiding angled pulls. Horizontal pull in all required directions option. Simultaneous vertical/horizontal pull option without moving the equipment. Universally suited to all vehicles with round shaped suspension housing. Sturdily built and compact.

RED PULLING ARM NOT INCLUDED.

### Dotazione standard | Standard equipment

- 1 campana superiore
- 1 disco diam. 70-80 mm
- 1 disco diam 85-95 mm
- 1 disco diam 100-110 mm
- 1 manina tiro con piastra
- Minuteria fissaggio
- Valigetta in plastica
- 1 upper bell
- 1 disc diam 70-80
- 1 disc diam 85-95
- 1 disc diam 100-110
- 1 pull claw with plate
- Small fastening items
- Plastic tool case



## KIT UNIVERSALE DI TIRO | UNIVERSAL PULLING SET Art. 160

### Dettagli | Details



Caratteristiche tecniche Technical specifications		160
Materiale, material: - Campana superiore Upper bell - Dischi Discs - Manina tiro con piastra Pull claw with plate - Minuteria Small item - Valigetta Tool case		fusione ghisa sferoidale globular cast iron fusione ghisa sferoidale globular cast iron 38Ncd4 forgiato + FE 37 orged 38Ncd4 + FE37 Fe37/C40  plastica plastic
Tenuta di tiro Pull strength	ton	8
Peso Weight	Kg	12

### Prodotti correlati | Related products



Art. 127 | Set di tiro per sospensioni  
Mac Pherson strut pulling kit



Art. D0510200 | Braccio di tiro  
Pull Arm





# MORSETTO DOPPIO | SIDE MEMBER CLAMP DOUBLE Art. 180

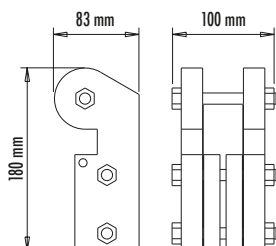

## Art. 180

Morsetto doppio per longherone.

Indispensabile per il tiro su longheroni longitudinali dotati di flange terminali. La speciale curva nelle due piastre consente di oltrepassare la flangia presente sul longherone e fissare solidamente il morsetto sul lamierato.

Adatto per: Golf III, Golf IV, Audi A3, Volvo, Peugeot, Mercedes 190, jeeps, VW Sharan, Ford Galaxy

## Double side member clamp.

Indispensable for traction on longitudinal side members equipped with terminal flanges. The special curve of the two plates permits exceeding the flange on the side member and tightly securing the clamp on the metal plate.

Suitable for: Golf III, Golf IV, Audi A3, Volvo, Peugeot, Mercedes 190, jeeps, VW Sharan, Ford Galaxy

Caratteristiche tecniche Technical specifications		180
Materiale Row Material		acciaio steel
Capacità di tiro Traction capacity	ton	8
Peso, Weight	Kg	3,6

Ganasce dentate  
intercambiabili  
Interchangeable jaws



## Accessori | Accessories



Art. 904 | Grillino  
Shackle

## Prodotti Correlati | Related Products



Art. 80 | Cavo di sicurezza  
Safety cable

Il cavo di sicurezza è fortemente raccomandato unitamente all'utilizzo di ogni tipo di morsetto e gancio di tiro.  
The use of the safety cable is strongly recommended together with all pull clamps and hooks.



# MORSETTO SEMPLICE | SIDE MEMBER CLAMP Art. 181

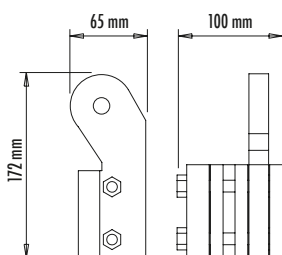

**Art. 181**  
 Morsetto semplice per longherone  
 Indispensabile per il tiro su longheroni longitudinali dotati di flange laterali e/o terminali. La speciale curva nella piastra consente di oltrepassare la flangia presente sul longherone e fissare solidamente il morsetto sul lamierato. Il morsetto può essere utilizzato sia per tiro a destra che a sinistra del longherone.

**Simple member clamp**  
 Indispensable for traction on longitudinal side members equipped with side and/or terminal flanges. The special curve of the two plates permits exceeding the flange on the side member and tightly securing the clamp on the metal plate. The clamp can be used for both right traction and left side member traction.



Ganasce dentate intercambiabili  
 Interchangeable jaws

Caratteristiche tecniche Technical specifications		181
Materiale Row Material		acciaio steel
Capacità di tiro Traction capacity	ton	8
Peso Weight	Kg	2,9

## Accessori | Accessories



Art. 904 | Grillino  
 Shackle

## Prodotti Correlati | Related Products



Art. 80 | Cavo di sicurezza  
 Safety cable

Il cavo di sicurezza è fortemente raccomandato unitamente all'utilizzo di ogni tipo di morsetto e gancio di tiro.  
 The use of the safety cable is strongly recommended together with all pull clamps and hooks.





# tools line

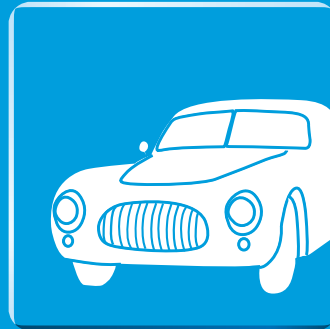

Una linea completa di strumenti, complementi, cavalletti, espositori e utensili indispensabili alle attività di carrozzeria, che agevolano il lavoro degli operatori.

Prodotti utilizzati e collaudati da migliaia di professionisti della riparazione in ogni parte del mondo, costruiti con criteri orientati alla durata e alla semplicità di utilizzo.

---

A complete line of instruments, complements, stands, displays and tools essential to bodywork activities, which facilitate the work of the operators.

Products used and tested by thousands of repair professionals worldwide, built with durability and ease-of-use criteria.



## KIT CHIAVI | SOCKET WRENCH KIT Art. 55



### Art. 55

Kit di testine speciali per la raddrizzatura di cerniere saldate. Consente la perfetta registrazione delle cerniere su oltre 18 modelli di autovetture di 10 marche automobilistiche, senza smontare la portiere. Queste testine speciali facilitano e velocizzano il montaggio delle portiere dopo ogni riparazione. Le testine intercambiabili vengono fissate sul manico universale mediante due viti e possono essere velocemente sostituite, per eseguire riparazioni su diversi modelli.

Il set di testine per cerniere è fornibile in 3 diverse composizioni, fornite in valigetta di plastica; OGNI TESTINA, NONCHÉ IL MANICO, È DISPONIBILE ANCHE SINGOLARMENTE (vedi tabella sul retro).

Socket wrench kit for welded hinge straightening. It makes possible to perfectly adjust car hinges even with the door fitted in position on over 18 car models on 10 different brands. This facilitates and speeds up the correct alignment of doors after pulling operation. The interchangeable heads are fitted onto a universal shaft by means of two socket head screws and can be quickly substituted to carry out repairs on different makes and models.

The Socket wrench hinge kit comes in 3 different combinations, packed in a plastic tool case; EVERY HEAD, AS WELL AS THE HANDLE, IS ALSO AVAILABLE SINGLE (see listing on the back).



## KIT CHIAVI | SOCKET WRENCH KIT Art. 55

### Dotazione standard | Standard equipment



Art. 55 Kit di 8 chiavi (7,5/9/9,4/11/11,5/12,5/15/17 mm) + manico + valigetta in plastica  
Kit of 8 sockets (7,5/9/9,4/11/11,5/12,5/15/17 mm) + shaft + plastic case

Caratteristiche tecniche Technical specifications		55
Materiale material: - Chiavi Wrenches - Manico + innesto Shaft + adapter		acciaio forgiato forged steel universale, in FE-zincato + acciaio universal, galvanized FE + steel
Peso Weight	Kg	7

Art.No Item nr	Testina per cerniere Head size	Modelli auto Car models
00050200	7,5DX mm	OPEL/CITROEN
00050300	9DX mm	AUDI/FORD/MERCEDES/OPEL/RENAULT 5
00050400	9,4DX mm	BMW/OPEL
00050500	11DX mm	PEGEOUT/RENAULT
00050600	11,5DX mm	FORD
00050700	12,5DX mm	CITROEN/FORD/VW
00050800	17DX mm	BMW
00050900	15DX mm	FORD GALAXI/VW SHARAN/SEAT ALHAMBRA
00051200	7,5SX mm	inclinazione inversa /reverse angle to OPEL/CITROEN
00051300	9SX mm	inclinazione inversa /reverse angle to AUDI/FORD/MERCEDES/OPEL/RENAULT 5
00051400	9,4SX mm	inclinazione inversa /reverse angle to BMW / OPEL
00051500	11SX mm	inclinazione inversa /reverse angle to PEGEOUT/RENAULT
00051600	11,5SX mm	inclinazione inversa /reverse angle to FORD
00051700	12,5SX mm	inclinazione inversa /reverse angle to CITROEN/FORD/VW
00051800	17SX mm	inclinazione inversa /reverse angle to BMW
00051000		manico universale / universal shaft

## KIT CHIAVI | SOCKET WRENCH KIT Art. 54F - 54T



Questo prodotto è fornibile nelle seguenti combinazioni con i seguenti codice articoli:  
This item is available in the following combinations according to these reference numbers:

- Art. 54F Kit di 4 chiavi (7,5 /17/11 /12,5 mm) + manico + valigetta in plastica  
Kit of 4 heads (7,5 /17/11 /12,5 mm) + shaft + plastic case
- Art. 54T Kit di 4 chiavi (9 /9,4 /11,5 /12,5 mm) + manico + valigetta in plastica  
Kit of 4 heads (9/9,4/11,5/12,5 mm) + shaft + plastic case





## MARTELLINO PER CERNIERE | EXTRACTOR Art. 56



### Dotazione standard | Standard equipment

- 1 martello estrattore
- 2 adattatori universali
- 1 extractor hammer
- 2 adaptors, universal

#### Art. 56

Martello per cerniere.

Estrattore per lo smontaggio delle spine, sia cave che piane, dalle cerniere delle vetture.

I due adattatori, compresi nella fornitura, consentono di estrarre tutti i tipi di spine, anche se arrugginite e bloccate.

Può essere impiegato sia dall'alto verso il basso, che dal basso verso l'alto.

Extractor to remove hinge pins from car doors.

Extractor to remove hollow and solid hinge pins from car doors.

With the two adaptors included in the kit, all kind of pins, even when old and rusted, can be easily extracted from all known car models and makes.

It can pull pins from the top to the bottom, and viceversa.

## FERMAPORTIERE PER AUTOVETTURE | DOOR HOLDER Art. 57



#### Art. 57

Fermaportiere per autovetture.

Ferma portiere per il bloccaggio della porta in caso di lavorazioni sui bordi esterni della porta stessa.

Piccolo attrezzo per il bloccaggio della porta in caso di lavorazioni sui bordi esterni della porta stessa. Consente di eseguire lavori di raddrizzatura, stuccatura, lucidatura ecc. sui bordi della portiera con la massima comodità e precisione.

Door Holder.

Small tool for fixing the car door in a open position during grinding, pulling, polishing and sanding. Also many deck lids can be held in the same manner.



## SUPPORTO PORTELLONI | REAR DOOR HOLDER Art. 58



### Art. 58

#### Supporto Portelloni.

Asta telescopica regolabile per il fissaggio dei portelloni posteriori di vetture monovolume, SUV, jeeps ecc. Consente di eseguire comodamente operazioni di riparazione sui bordi esterni del portellone.

#### Rear Door Holder.

Adjustable telescopic rod for supporting rear doors of SUV, pickups, jeeps, etc. Permits easy repair operations on outer edges of door.

Caratteristiche tecniche Technical specifications		58
Materiale Material		ferro iron
Lunghezza minima Minimum length	mm	590
Lunghezza massima Maximum length	mm	1390
Peso Weight	Kg	1,70



## SUPPORTO COFANO | CAR HOOD HOLDER Art. 59



### Art. 59

Asta telescopica, regolabile ferma cofano.

Realizzata in acciaio, dotata di 2 tamponi in gomma alla base ed estremità.

Ideale per tenere alzato il cofano del veicolo in una posizione maggiore rispetto all'asta di sostegno originale.

Telescopic rod, adjustable hood stop.

Made of steel, equipped with 2 rubber pads at both ends.

Ideal for keeping the hood of the vehicle raised in a higher position than the original support rod.

#### Caratteristiche tecniche Technical specifications

Caratteristiche tecniche Technical specifications		59
Materiale Material		acciaio steel
Lunghezza minima Minimum length	mm	600
Lunghezza massima Maximum length	mm	1500
Peso Weight	Kg	2





# GANCI | HOOKS Art. 90÷95



Art. 90





Art. 91

Art. 92

Art. 93 Accorcias catena  
Chain shorten

Art. 94 Doppio gancio forcella  
Chain shorten 2 hooks

Art. 95 Accorcias catena doppia manina  
Chain shorten double claw

	Codice Code	Resistenza al trazione Resistance to traction	U <sub>(k=2)</sub>	Peso Weight
	Art. 90	7 ton	-	Kg 0,65
	Art. 91	5 ton	2.063	Kg 0,48
	Art. 92	7 ton	1.928	Kg 0,55
	Art. 94	5 ton	1.805	Kg 1,16
	Art. 95	3 ton	986	Kg 1,50





## RAGNO | SPIDER Art. 99

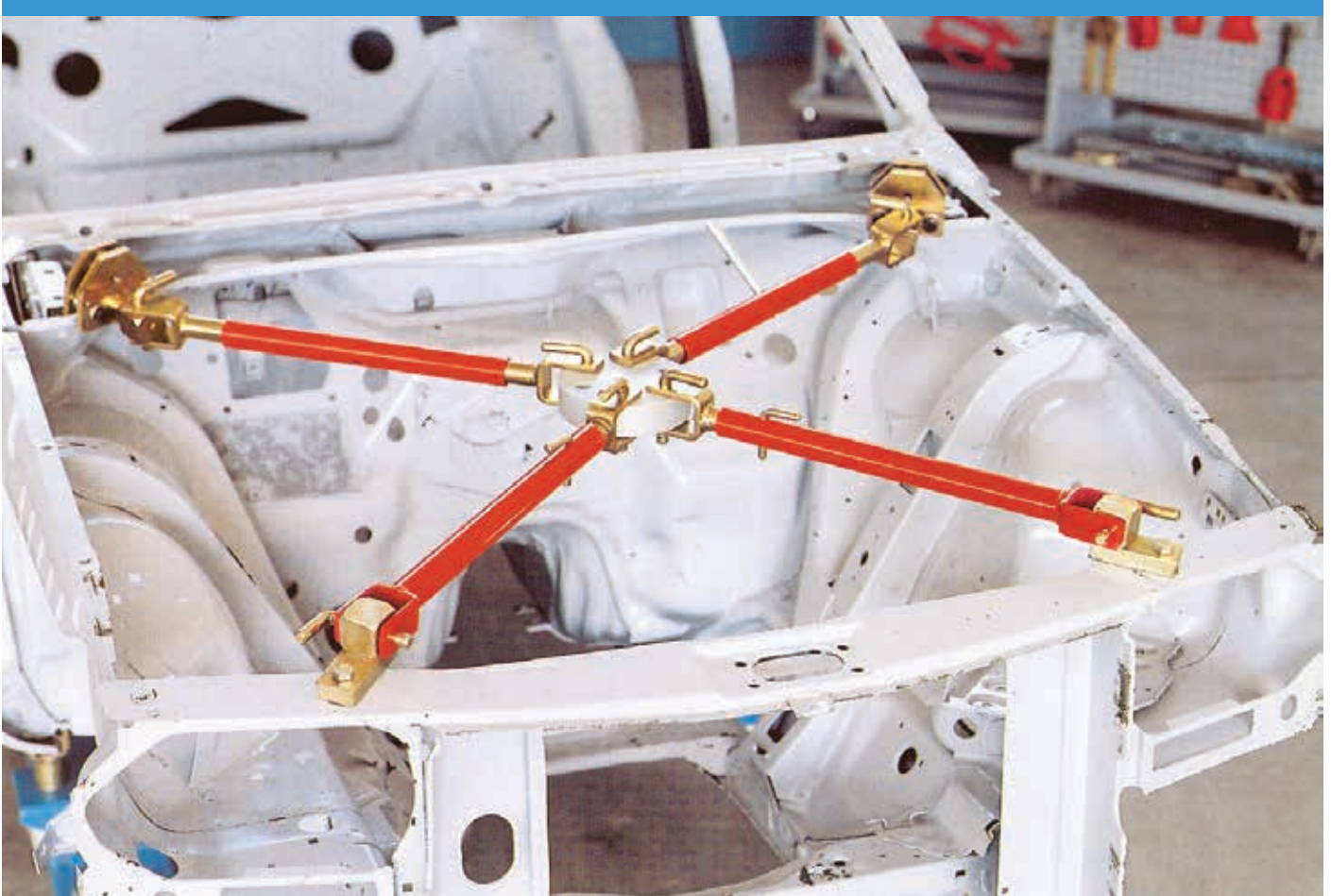

### Art. 99

Piccola attrezzatura di raddrizzatura per vani carrozzeria. Apparecchiatura di tiro e spinta a quattro bracci per impieghi universali in operazioni minori di raddrizzatura dei vani carrozzeria. Indispensabile in ogni officina carrozzeria.

### Principio di funzionamento

Due bracci estensibili fungono da ancoraggio e due bracci operanti filettati eseguono una azione di tiro o spinta a seconda del senso di rotazione applicato manualmente sul tubo esterno. Il disco centrale funge da fulcro di distribuzione ed assorbimento delle forze sviluppate. Grazie agli appositi rinvii a 90° applicabili ai morsetti, è possibile ancorare il RAGNO anche a lamiere in posizioni perpendicolari rispetto all'asse operativa.

---

Body frame pulling and pushing equipment. Four-arm pulling and pushing equipment for all-purpose use in minor straightening jobs on body frames. This innovative device is essential for every body shop.

### Operating principle

Two extensible arms act as anchors, and two operating arms pull or push according to the rotation direction set by hand on the outer pipe, by means of an internal thread. The central disk acts as a fulcrum to distribute and absorb the forces. Thanks to the special 90° transmission applied to the clamps, it is even possible to fasten the SPIDER to pieces of metal perpendicular to the operating direction.



## RAGNO | SPIDER Art. 99

### Applicazioni | Use mode

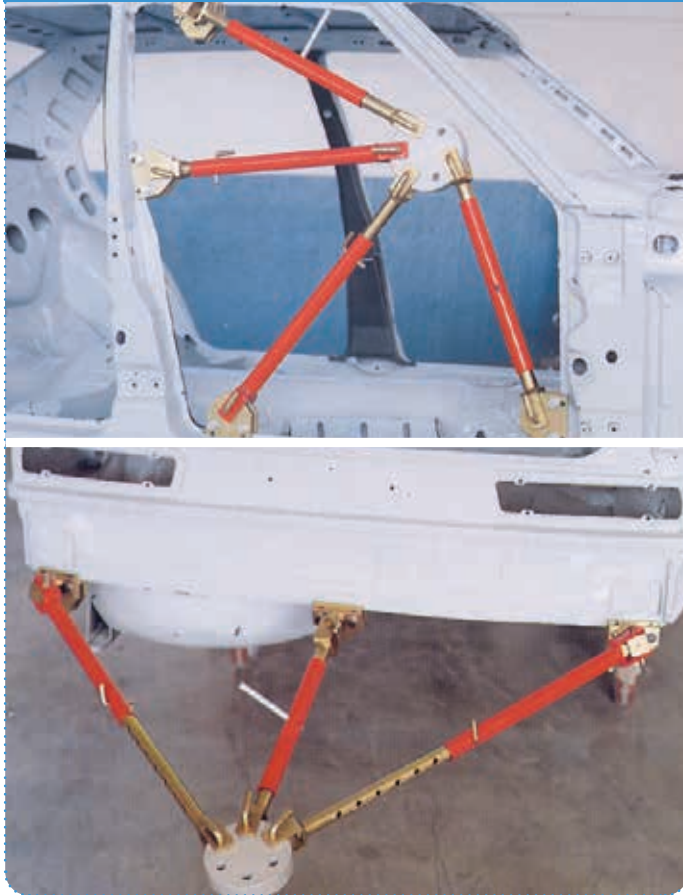

Caratteristiche tecniche Technical specifications		99
Materiale Row Material		acciaio speciale special steel
Apertura minima in diagonale Minimum diagonal opening	mm	1180
Apertura massima in diagonale Maximum diagonal opening	mm	1700
Azionamento estensione bracci Arm extending operated by		manuale manually
Peso Weight	Kg	24

### Dotazione standard | Standard equipment

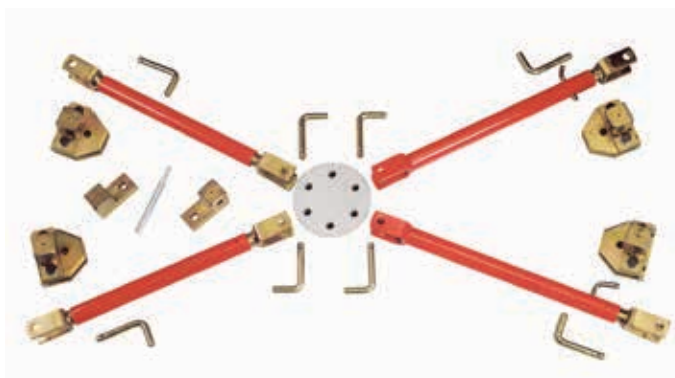

Il ragno e' composto da:

- 2 bracci estensibili di tiro e spinta con vite filettata
- 2 bracci di raccordo ad avvicinamento rapido bloccabili mediante spinta
- 4 morsetti con doppie ganasce dentate intercambiabili
- 4 blocchi snodati di rinvio a 90° applicabili ai morsetti
- 2 blocchi snodati con piastra forata per ammortizzatori
- 1 pezzo centrale di collegamento in alluminio diametro 150 mm
- 8 perni diam. 14 mm. con sfera di bloccaggio per l'assemblaggio del ragno
- 2 perni diam. 10 mm per bloccare i due bracci telescopici alla lunghezza desiderata
- 1 perno di azionamento

Tool composition:

- pull push arms with internal thread
- 2 extendible arms
- 4 clamps with double interchangeable jaws
- 4 x 90° transmission blocks
- 2 x 90° transmission plates to shock absorbers
- 1 central disk diam 150 mm
- 8 pins diam 14 mm
- 2 pins diam 10 mm
- 1 operating shaft





## BLOCK Art. 100

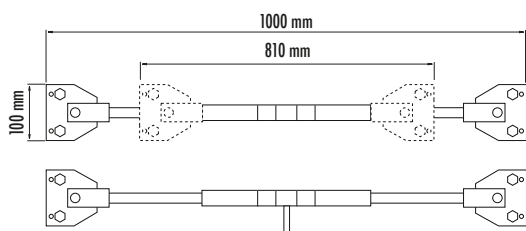

### Art. 100

Morsetti universali per vani porte vetture.

Questo tendiporta regolabile impedisce che i vani porta si deformino durante le operazioni di tiro. I quattro morsetti snodati permettono di rendere universale l'attrezzo e, una volta montato, di chiudere perfettamente la portiera in fase di lavoro.

I morsetti zigrinati, in acciaio speciale trattato, sono intercambiabili per poter essere sostituiti una volta usurati.

La rapidità di montaggio ed il bloccaggio perfetto fanno del "BLOCK" un attrezzo di grande utilità nel lavoro di carrozzeria.

Universal door clamps for motor vehicles.

These door clamps connected with special extensible adjusters have been designed to ensure that during body straightening operations the door openings are not deformed. The articulated clamps make the use of this device universal and, once they are mounted in position, allow the door to be shut while working.

The jaws are in special treated steel and can be replaced when they are worn out.

The quick mounting and the perfect clamping make of the "BLOCK" a very useful device for the body-work.

Caratteristiche tecniche Technical specifications		100
Apertura massima Max length	mm	1000
Apertura minima Min length	mm	810
Peso Weight	Kg	11,3



## MONOBLOCK Art. 102

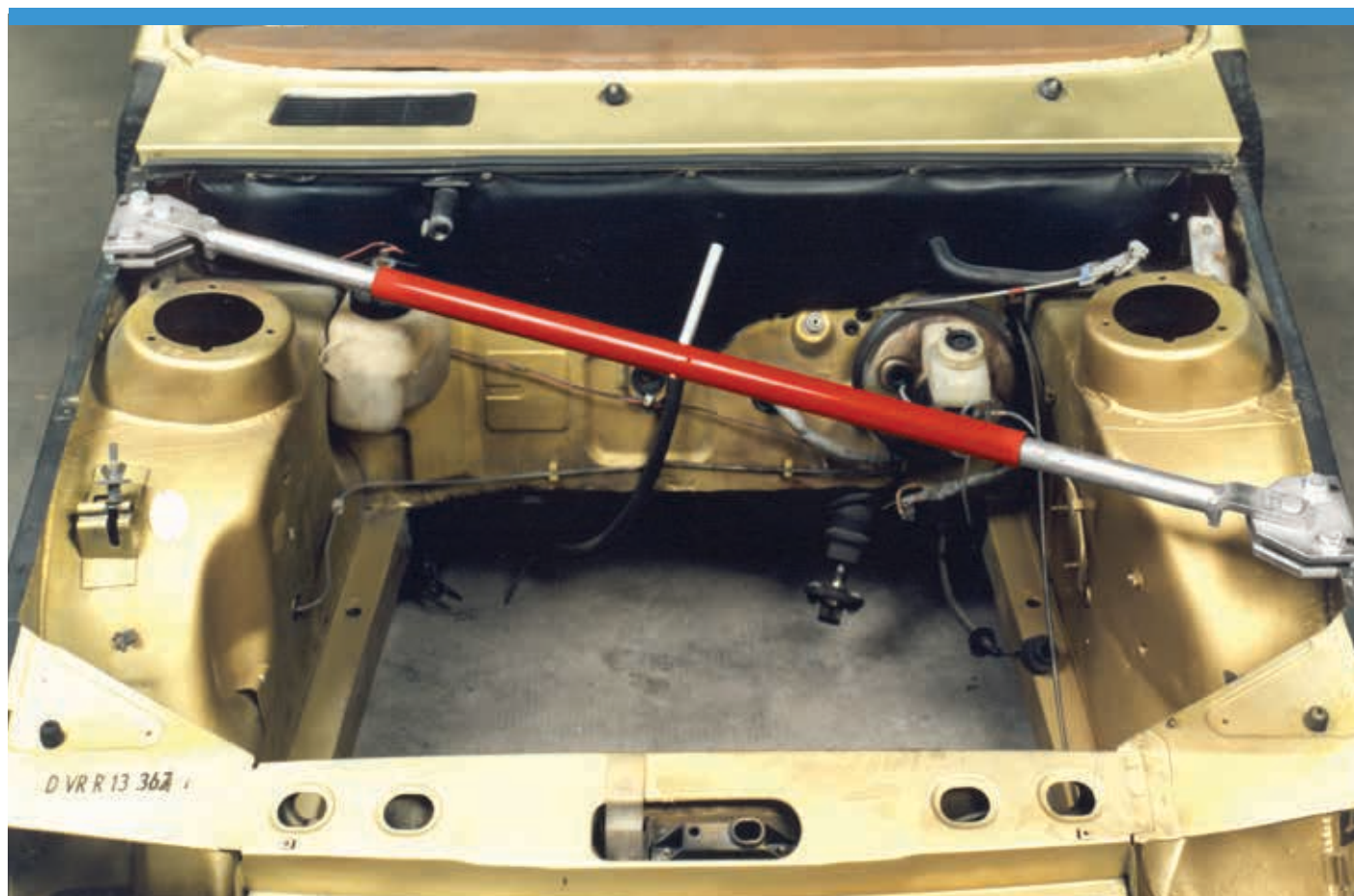

### Art. 102

Morsetti universali per vani motore e bagagliai.

Questi 2 morsetti montati su tubo estensibile, sono stati studiati per assicurare che, durante il tiro, non si deformino i vani motore e bagagliaio delle vetture.

La lunghezza del MONOBLOCK lo rende adatto anche per vani vetture di grandi dimensioni. Dotato di morsetti intercambiabili.

Universal holding clamps for trunk openings and engine locations.

This set of clamps, connected with extensible adjusters, was designed to insure that during body straightening operations the trunk and engine openings are not deformed.

Because of its special length it is suitable to large size cars with big trunks door motor openings. Equipped with interchangeable jaws.

### Caratteristiche tecniche Technical specifications

		102
Apertura massima Max length	mm	1600
Apertura minima Min length	mm	1080
Peso Weight	Kg	7,3

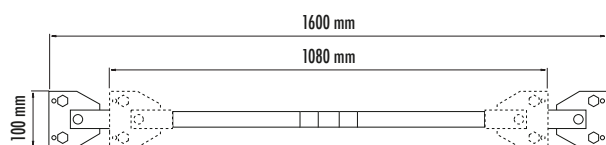





## TRAPEZIO Art. 111

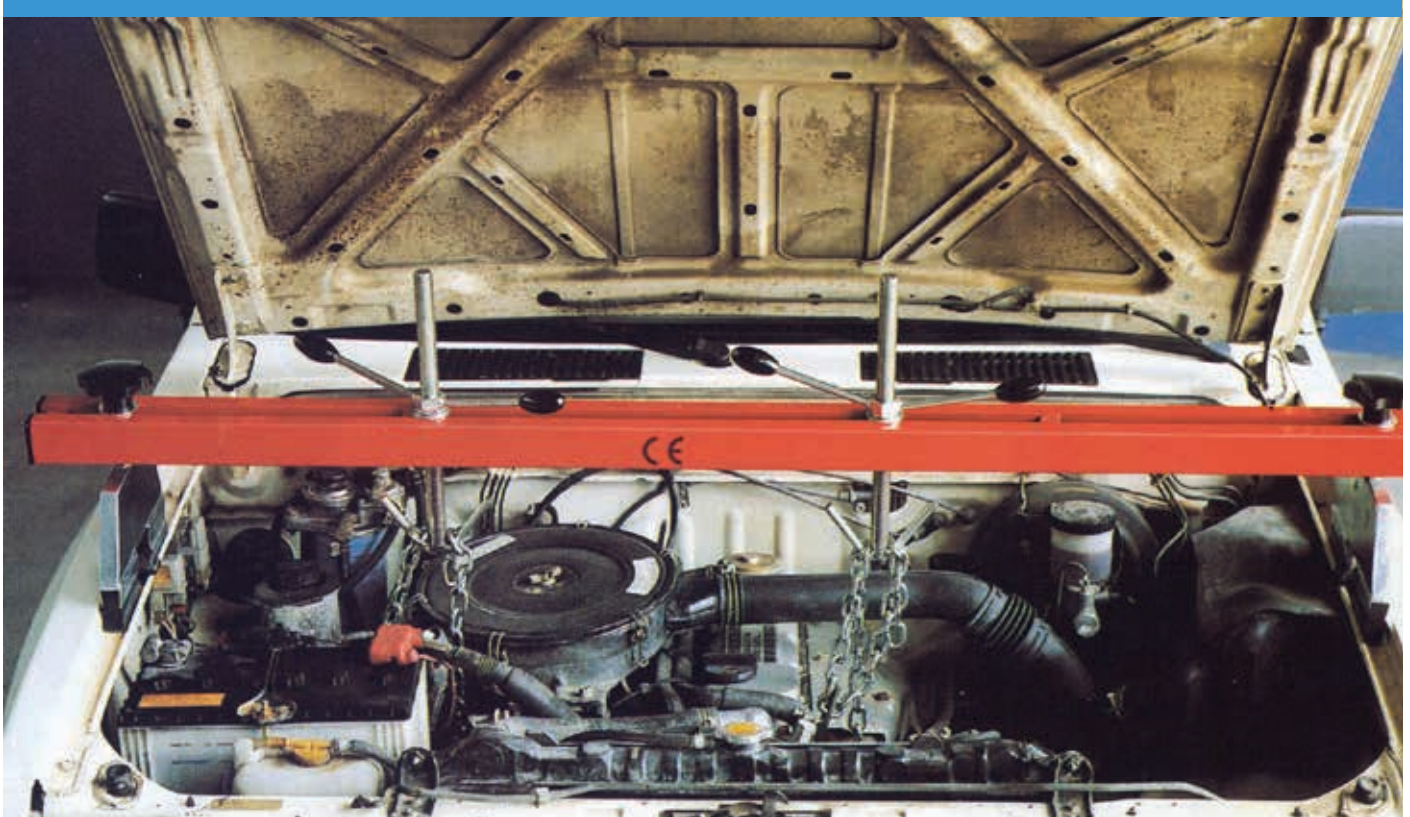

Art. 06031000 | Optional  
Supporti orientabili per art. 111  
Adjustable stands for item 111

### Art. 111

Traversa di sollevamento per motore, dotata di due ancore filettate, di posizione regolabile. Consente di ancorare e sollevare il motore, per eseguire riparazioni meccaniche senza dovere estrarre il motore dalla carrozzeria.  
È CONFORME AI REQUISITI DIRETTIVA MACCHINE (2006/42/CE).

Supports the engine during repair, thus allowing parts replacement without removing the engine. Fully adjustable to fit any car. Includes two adjustable chain slings.  
MEETS THE REQUIREMENTS OF ALL RELEVANT EUROPEAN DIRECTIVES (2006/42/CE).

Caratteristiche tecniche Technical specifications		111
Materiale Raw Material		acciaio steel
Portata max Max lifting capacity	Kg	300
Lunghezza max Max length	mm	1500
Supporti Stands		fissi fixed
Peso Weight	Kg	14





## SUPPORTI ORIENTABILI | ADJUSTABLE STANDS Art. 111S



Supporti orientabili compresi  
Adjustable stands included



### Art. 111S

Speciale traversa di sollevamento per motore con supporti orientabili per impiego su vetture con passaruota fortemente inclinati.

La traversa del Trapezio rimane comunque perpendicolare all'asse di tiro.

Completo di 2 ancore filettate e 2 catene di sollevamento, consente di ancorare e sollevare il motore, senza estrarlo dalla carrozzeria.

È dotato di supporti inclinabili e può quindi essere utilizzato anche su autovetture con vano motore fortemente curvato, come ad esempio: Toyota Yaris, Lancia Musa, VW Sharan e T5. È CONFORME AI REQUISITI DIRETTIVA MACCHINE (2006/42/CE).

Supports the engine during repair. The "S"-model is equipped with adjustable stands for use on vehicles with very sloped wheelhouse edges, while the crosspiece always remains horizontal. Fully adjustable to fit any motor vehicles, it allows parts replacement without removing the engine. Includes two adjustable chain slings and two chains.

Can be easily applied and can be set in many different positions.

Thanks to its adjustable supports it is suitable for heavily curved engine housings, such as: Toyota Yaris, Lancia Musa, VW Sharan and T5.

ITEM 111/S MEETS THE REQUIREMENTS OF ALL RELEVANT EUROPEAN DIRECTIVES (2006/42/CE).

Caratteristiche tecniche, Technical specifications		111S
Materiale Raw Material		acciaio steel
Portata max Max lifting capacity	Kg	300
Lunghezza max Max length	mm	1500
Supporti Stands		orientabili adjustable
Peso Weight	Kg	14



## MAXICAR Art. 115

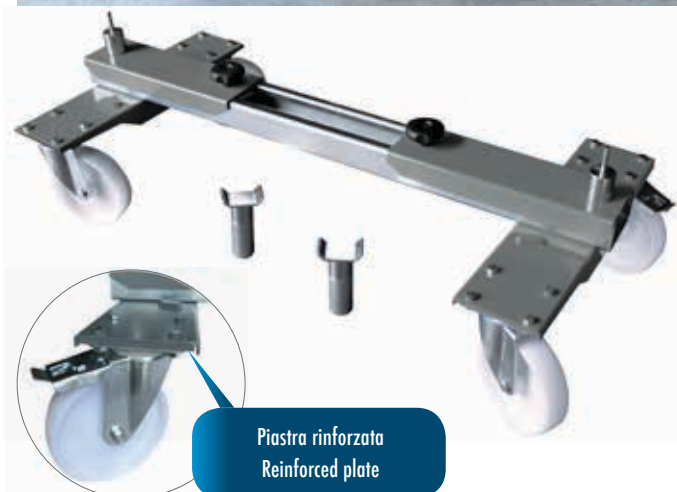

Piastra rinforzata  
Reinforced plate

### Art. 115

Pratico carrello per la movimentazione di scocche e di vetture danneggiate (senza ruote). Bracci telescopici regolabili. Le ruote pivotanti di grande diametro (20 cm), di cui una munita di freno, sono resistenti alle temperature dei forni di verniciatura.

Il MAXICAR può essere dotato di 3 diversi tipi di attacchi:

- a perno (standard)
- a "U" (standard)
- a morsa (art. 103 optional)

MAXICAR is practical trolley for transportation of car bodies and damaged motor vehicles around body shops and mechanical shops.

Its telescopic arms can be adjusted in different positions, to allow the loading of motor cars with different sizes. The large diameter wheels (20 cm), one of which is equipped with a brake, offer great stability and are heat resistant.

MAXICAR features 3 different vehicle supports:

- pins (standard)
- U-plates (standard)
- clamps (item 103, optional)

### Dotazione standard | Standard equipment

- Carrello con bracci telescopici
- 2 prolunghe filettate
- 2 attacchi con perni
- 2 attacchi con piattello a U
- Trolley with telescopic arms
- 2 threaded extension tubes
- 2 threaded pin adaptors
- 2 threaded adaptors with U plate

Caratteristiche tecniche Technical specifications		115
Max. Larghezza Max. width	mm	1800
Min. Larghezza Min. width	mm	1300
Max interasse fra attacchi Max support distance	mm	1740
Min. interasse fra gli attacchi Min distance between brackets	mm	810
Interasse fra le ruote Wheelbase between castors	mm	1100
Altezza Max. con morsetti + prolunga Max. height with clamp + extension	mm	560
Ruota con freno Wheel with brake		1
Portata max Max loading	Kg	1000
Peso Weight	Kg	50



## MAXICAR Art. 115 + Art. 103

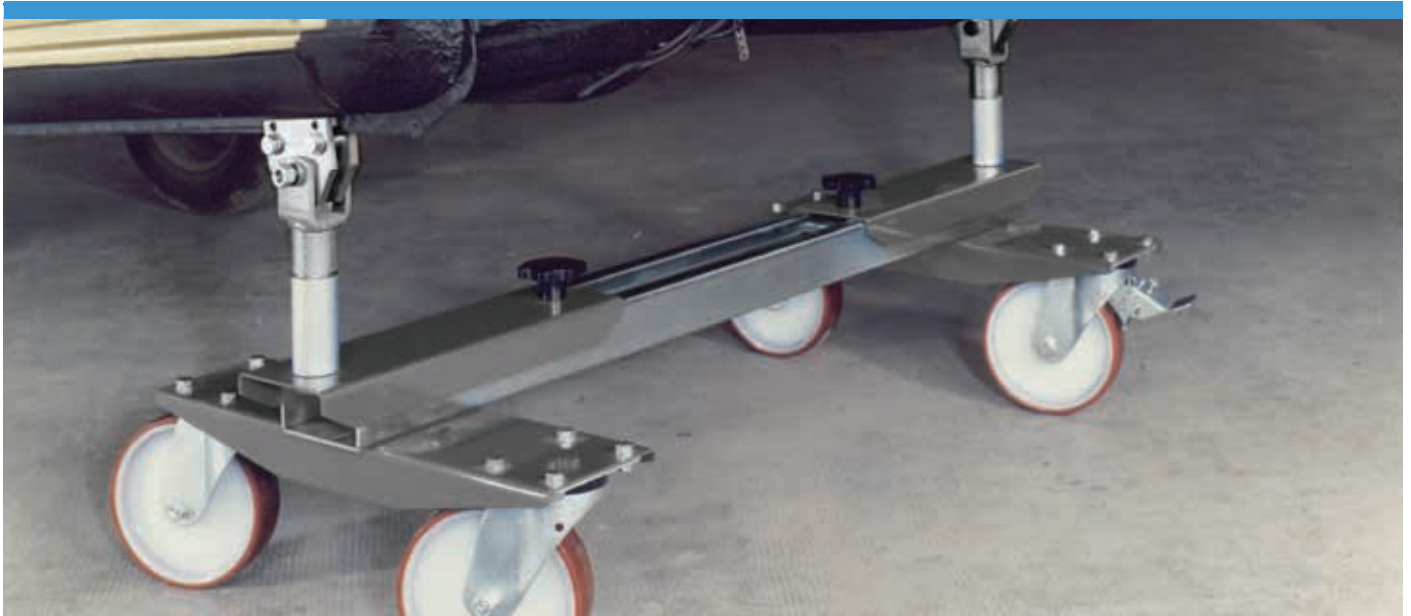

### Art. 115 + Art. 103

L'utilizzo dei morsetti per bordino sottoporta, art. 103, unitamente al Maxicar è consigliabile quando si devono movimentare veicoli di grandi dimensioni su pavimenti industriali, ove sia richiesta maggiore sicurezza di ancoraggio, per evitare la caduta del veicolo dal carrello.

Art. 103 Push Pull è un optional non compreso nella fornitura del Maxicar e deve essere ordinato separatamente, se richiesto.

The use of the sill clamps item 103 together with the Maxicar is strongly recommended, when large size vehicles are to be transported on industrial floors, whenever a safer anchoring of the car shell is necessary, to prevent its falling down from the trolley.

The item 103 Push Pull is an optional not included in the standard delivery of Maxicar and should be ordered separately, if requested.

### Accessori | Accessories



Art. 103

**Push pull**  
Set di 2 pezzi di morse con attacco filettato per bordino sotto porta.  
Set with 2 ps clamps with threaded.  
Connection for sill anchoring

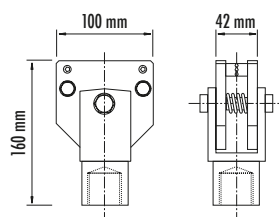

Art. 103/V

**Push plug**  
Set di 2 pezzi di tamponi con attacco filettato.  
Set with 2 ps pads with threaded.

### Prodotti correlati | Related products



Art. 116 | SUV TROLLEY



Art. 117 | SVELTO





## SUV TROLLEY Art. 116



Art. 116  
Carrello di eccezionale robustezza per la movimentazione delle scocche di SUV, Pick Up, Minibus e simili all'interno delle carrozzerie.  
Supporto piattelli regolabile e ruote di elevata portata con sistema di bloccaggio.

Heavy duty car body handling trolley suitable for the quick and safe transportation of damaged SUV vehicles, pick ups, vans and similar around body shops and mechanical shops.  
Complete with 2 rubber pads and 3 support extensions, fitted with wheel brake.

### Accessori | Accessories



Art. 1035 Push pull per art. 116  
Set di 2 pezzi di morse con attacco filettato e adattatori per bordino sotto porta.  
Push pull for item 116  
Set with 2 ps clamps with threaded connection and adapter for sill anchoring

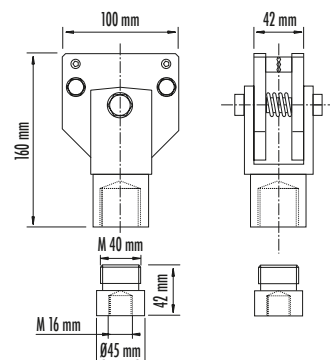



## SUV TROLLEY Art. 116

### Dettagli | Details



Caratteristiche tecniche Technical specifications		116
Materiale Raw Material		acciaio zincato e verniciato galvanized and painted steel
Max interasse fra attacchi Max support distance	mm	1500
Min. interasse fra gli attacchi Min distance between brackets	mm	1390
Interasse fra le ruote Wheelbase between castors	mm	400
Altezza Min Min. height	mm	400
Ruota con freno Wheel with brake		1
Diametro delle ruote Diameter wheels	mm	200
Portata Capacity		Interasse fra i supporti max 1390 mm capacità kg. 3100 Max distance between supports 1390 mm capacity kg. 3100 Interasse fra i supporti max 1500 mm capacità kg. 2400 Max distance between supports 1500 mm capacity kg. 2400
Peso Weight	Kg	68

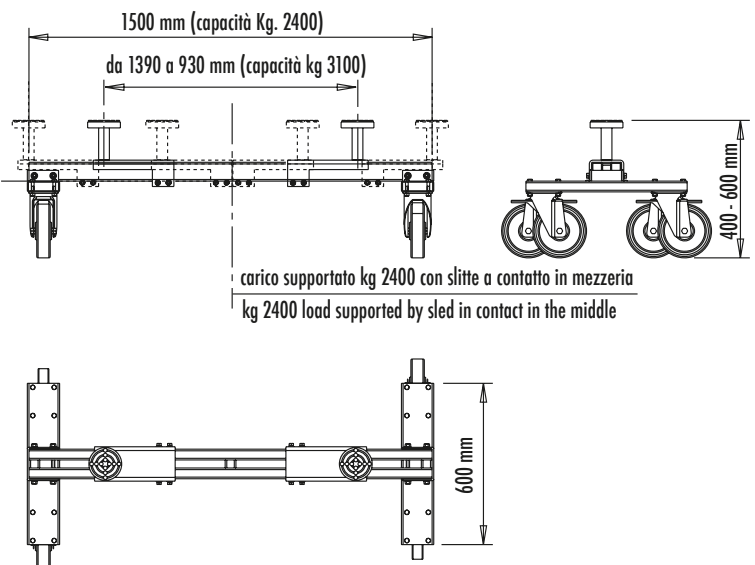

### Dotazione standard | Standard equipment

- 1 carrello con ruote pivotanti, di cui 1 con freno
- 2 piattelli con rivestimento in gomma
- 2 perni L 90mm
- 2 serie di prolunghe per piattelli L=95 mm L= 125 mm

- 1 trolley with swivel wheels one of which with brake
- 2 rubber pads
- 2 pin supports L= 90mm
- 2 extensions threaded L=95 mm L=125mm





## SVELTO Art. 117

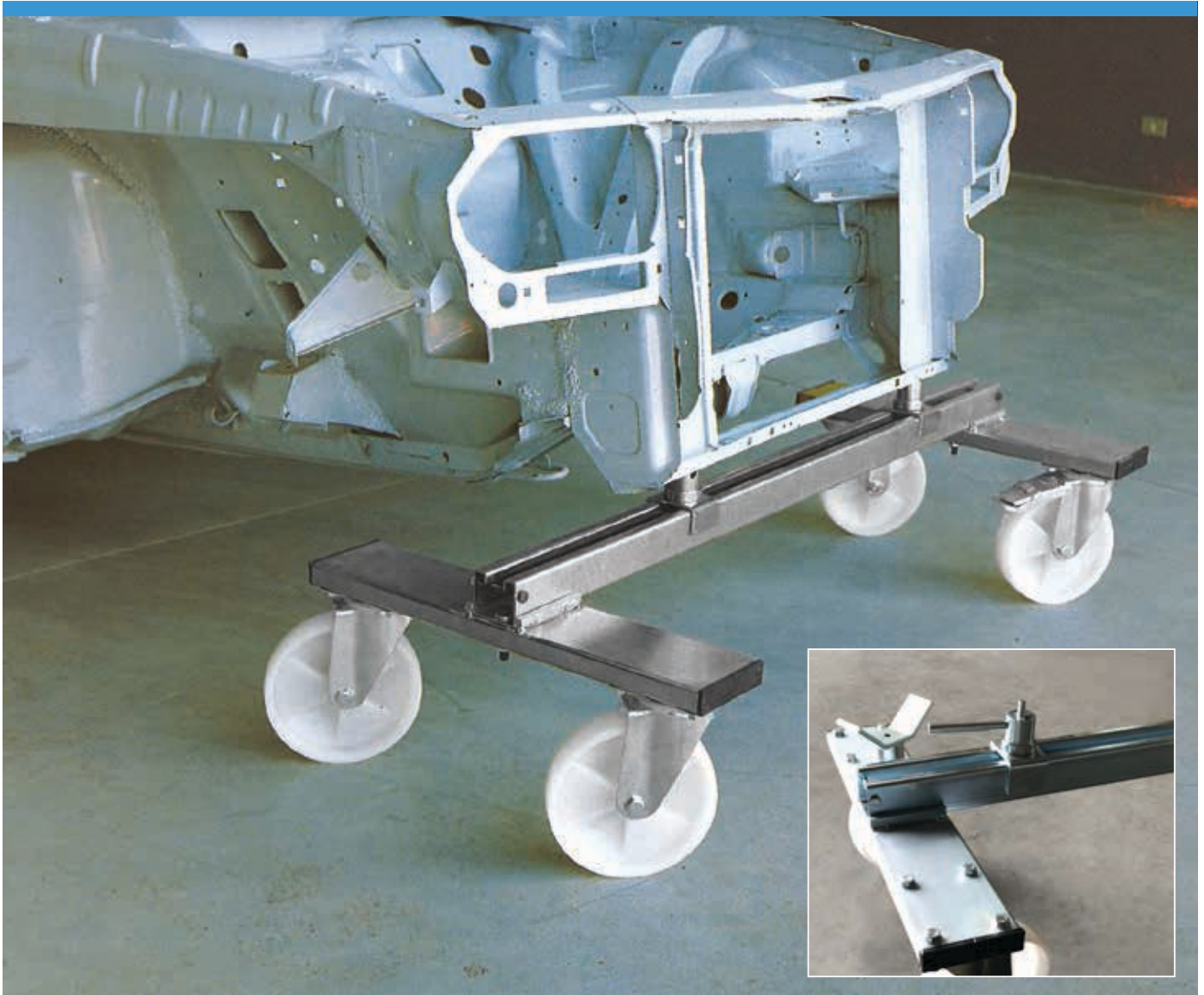

### Art. 117 - Svelto

Carrello movimentazione scocche realizzato in lamiera zincata, completo di appoggi a cavalletto e a perno, dotato di freno ruota, portata massima 1.000 Kg.

**Affidabilità' e praticita':** consente il bloccaggio degli appoggi a cavalletto nella posizione desiderata, per una maggiore sicurezza dell'operatore. La barra di appoggio è sfruttabile per tutta la lunghezza (1250 mm) consentendo la movimentazione anche di vetture di notevoli dimensioni.

**Sicurezza:** completo di ruota con freno di serie, per bloccare il carrello in posizione.

**Economico:** Svelto è completamente smontabile e viene fornito in un comodo imballo di cartone neutro pratico ed economico per spedizione e magazzino.

### Item 117 - Svelto

Car Body Handling Trolley made from galvanised steel, complete with stand and pin supports, fitted with wheel brake, maximum capacity 1.000 Kg.

**Reliability and convenience:** the stand supports can be locked in the desired position for greater operator safety. The whole length of the support bar (1250 mm) Can be used, thus allowing even very large vehicles to be transported.

**Safety:** complete with wheel and standard brake to block the trolley in position.

**Economical:** Svelto can be totally dismantled and is supplied in a convenient neutral board box: practical and economical for storage and despatch.





## SVELTO Art. 117

### Dettagli | Details

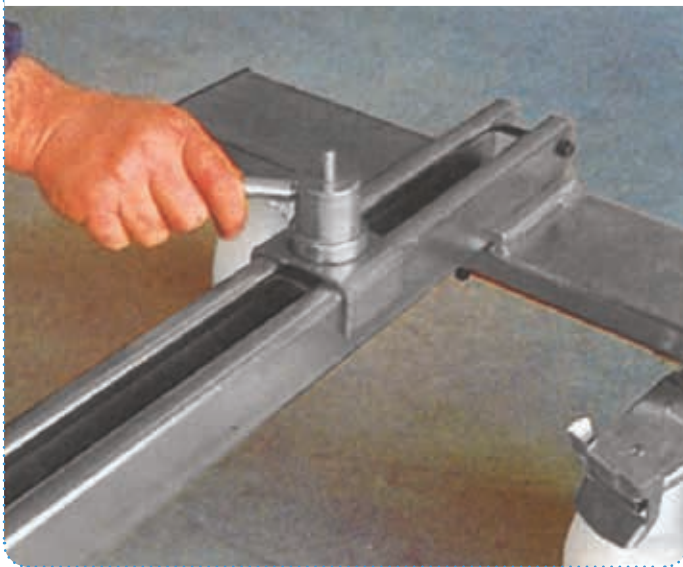
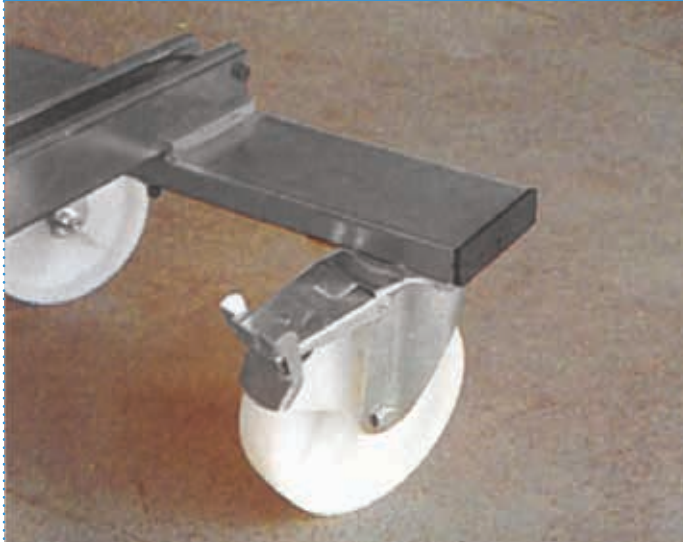

Caratteristiche tecniche Technical specifications		117
Materiale Raw Material		Acciaio zincato Zink plated steel
Ruota con freno Wheel with brake		1
Portata max Max loading	Kg	1000
Peso Weight	Kg	29

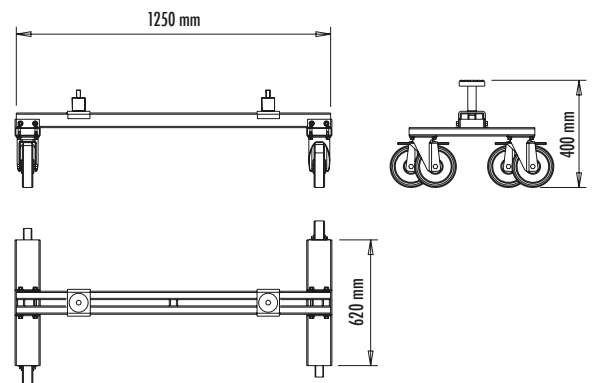

### Prodotti correlati | Related products



Art. 115 | MAXICAR



Art. 116 | SUV TROLLEY



## ASSO Art. 124



### Art. 124

Cavalletto di robusta costruzione per l'appoggio di vetri parabrezza di grandi dimensioni. La catena di fissaggio consente un'apertura massima dei supporti di 1000 mm. Bracci di appoggio dotati di protezione in gomma piuma. Viene fornito montato e pronto all'uso.

Study panel rest for large-size windshields. Thanks to the retention chain, the support can be opened by a maximum 1000 mm. The support arms feature foam rubber protection. Supplied assembled and ready for use.

Caratteristiche tecniche Technical specifications		124
Materiale Raw Material		ferro verniciato coated iron
Dimensioni max ingombro Max working dimensions	mm	800 x 1250 H
Regolazione altezza Height adjustment		mediante catenella by means of chain
Protezione tubi Protection to support arms		gomma piuma foam rubber
Peso Weight	Kg	9,4

## Accessori | Accessories



Art. 06500700 | Supporto per i vetri  
Support for glasses



## TERENCE Art. 124V

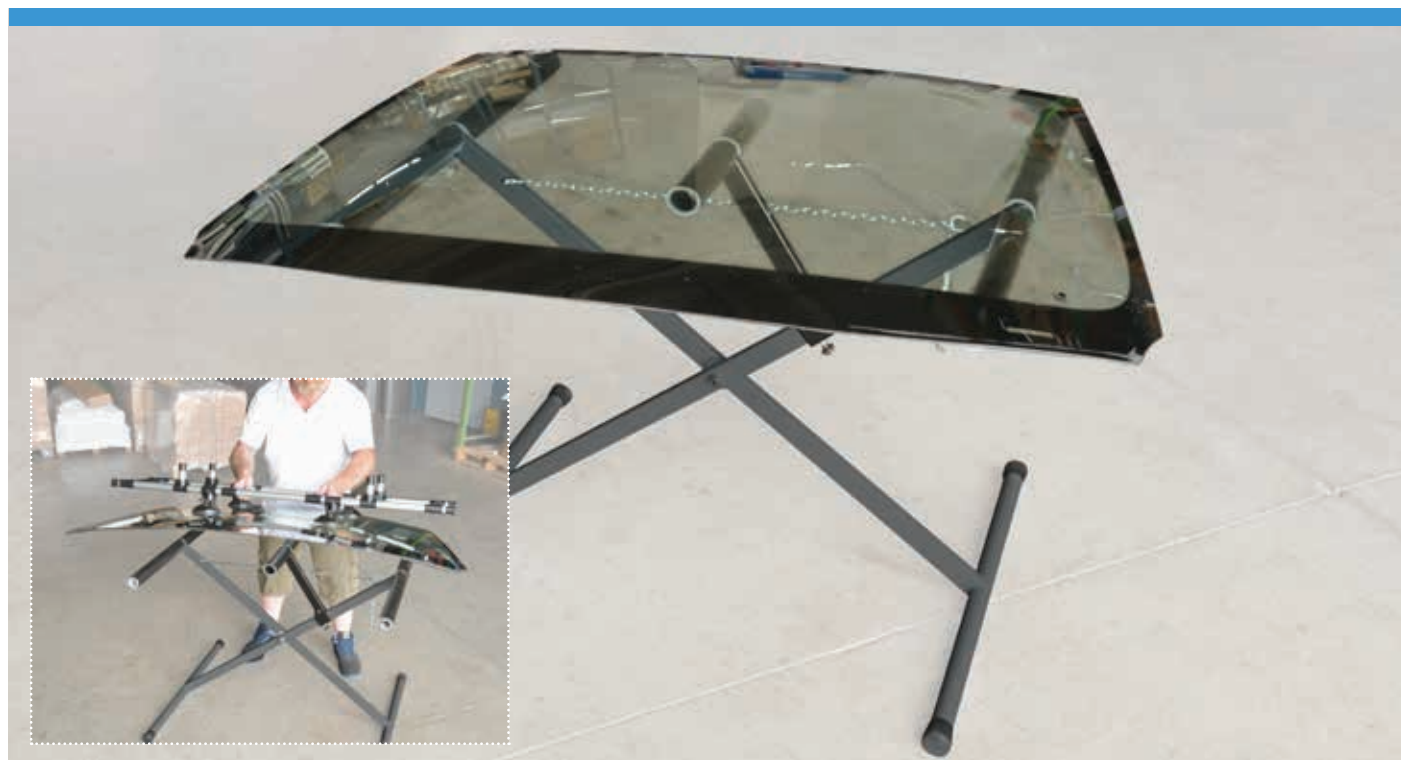

### Art. 124V

Cavalletto robusto per l'appoggio di vetri parabrezza di grandi dimensioni. La catena di fissaggio consente un'apertura massima del supporto di 1000 mm. I bracci di appoggio sono dotati di protezione in gomma piuma. Il supporto è necessario per le lavorazioni dei vetri. Viene fornito montato e pronto all'uso.

Study panel rest for the support of long size windscreens. Thanks to the chain, the support can be open by a maximum 1000 mm. The support arms feature foam rubber protection. Support is necessary for the complete processing of the glass. Supplied assembled and ready for use.



Caratteristiche tecniche Technical specifications		124V
Materiale Raw Material		ferro verniciato coated iron
Dimensioni max ingombro Max working dimensions	mm	800 x 1250 H
Regolazione altezza Height adjustment		mediante catenella by means of chain
Protezione tubi Protection to support arms		gomma piuma foam rubber
Peso Weight	Kg	9,7





## CAVALLETTO | PANEL REST Art. 125



### Art. 125

Cavalletto per l'appoggio di parabrezza e pannelli in lamiera. Regolabile in altezza e completamente smontabile. Di minimo ingombro, richiede ridottissimi costi di immagazzinaggio e spedizione.

Panel rest for window glasses and metal panels. Adjustable height, completely dismountable. Its very compact dimensions require only very low storage and shipping costs.

Caratteristiche tecniche Technical specifications		125
Materiale Raw Material		ferro zincato zinc plated iron
Dimensioni max ingombro Max working dimensions	mm	1000 x 1120 H
Massima apertura Maximum opening	mm	930
Regolazione altezza Height adjustment		mediante catenella by means of chain
Protezione tubi Protection to support arms		gomma rubber
Peso Weight	Kg	11



## CAVALLETTI | PANELS REST Art. 125E - Art. 125P



### Art. 125E

Cavalletto economy - Cavalletto per l'appoggio di lastre parabrezza e pannelli in lamiera. Regolabile in altezza, viene fornito già assemblato

Panel rest economy - Panel rest for window glasses and metal panels. Adjustable height, delivered completely assembled

Caratteristiche tecniche Technical specifications		125E
Materiale Row material		tubolare verniciato painted tubular steel
Dimensioni max ingombro Max working dimensions	mm	1000 x 1120 H
Massima apertura Maximum opening	mm	930
Regolazione altezza Height adjustment		mediante catenella by means of chain
Protezione tubi Protection to support arms		gomma rubber
Peso   Weight	Kg	10,4



Art. 125P

### Art. 125P

Cavalletto con piano - per l'appoggio di parabrezza e pannelli in lamiera. Regolabile in altezza, è dotato di un comodo piano di appoggio in lamiera.

Panel rest with service tray - for window glasses and metal panels, adjustable height.

Caratteristiche tecniche Technical specifications		125P
Materiale Row material		tubolare verniciato painted tubular steel
Dimensioni max ingombro Max working dimensions	mm	1000 x 1120 H
Massima apertura Maximum opening	mm	da 640 a 800 from 640 to 800
Protezione tubi Protection to support arms		gomma rubber
Regolazione altezza Height adjustment		mediante pannello by means of panel
Dimensioni pannello Panel dimensions		400 x 835
Peso   Weight	Kg	14



## VENTOSA Art. 199



### Art. 199

#### Martello pneumatico di tiro.

Il vuoto che si crea all'interno della ventosa di gomma, grazie ad una pompa Venturi inserita nel manico, consente una solida presa sul lamierato e la successiva eliminazione di ammaccature estese, ma non profonde in pochi minuti.

Il martello VENTOSA sostituisce il tradizionale sistema "tirabolli" più verniciatura, o riduce l'estensione dell'area danneggiata sulla quale è necessario intervenire con saldatura spotter e martello battente, consentendo un grande risparmio di tempo e costi.

#### Vacuum slide hammer for paintless repair.

This air slide hammer is the perfect tool for paintless repair: extended, yet not too deep dents can be quickly and effectively pulled out thanks to the vacuum created inside the suction cup by means of a Venturi pump installed in the handle.

The slide hammer VENTOSA substitutes the traditional dent pulling by means of spotter and hammering for a perfect paintless repair, or reduces the extension of the damaged panel area where it is necessary to apply spotter welding and subsequent repair and painting technique. Ventosa provides great saving and profitability.





## VENTOSA Art. 199

### Applicazioni | Use mode



Caratteristiche tecniche Technical specifications		199
Tenuta ottenuta mediante pompa Venturi Holding power created by Venturi pump	Kg	150
Diametro ventose Cup size (Diameter)	mm	1x115 + 1x155
Alimentazione Driving		pneumatica (max 6 bar) pneumatic supply (max 6 bar)
Peso Weight	Kg	3,2



## KIT MARTELLO DI TIRO | SLIDE HAMMER SET Art. 200

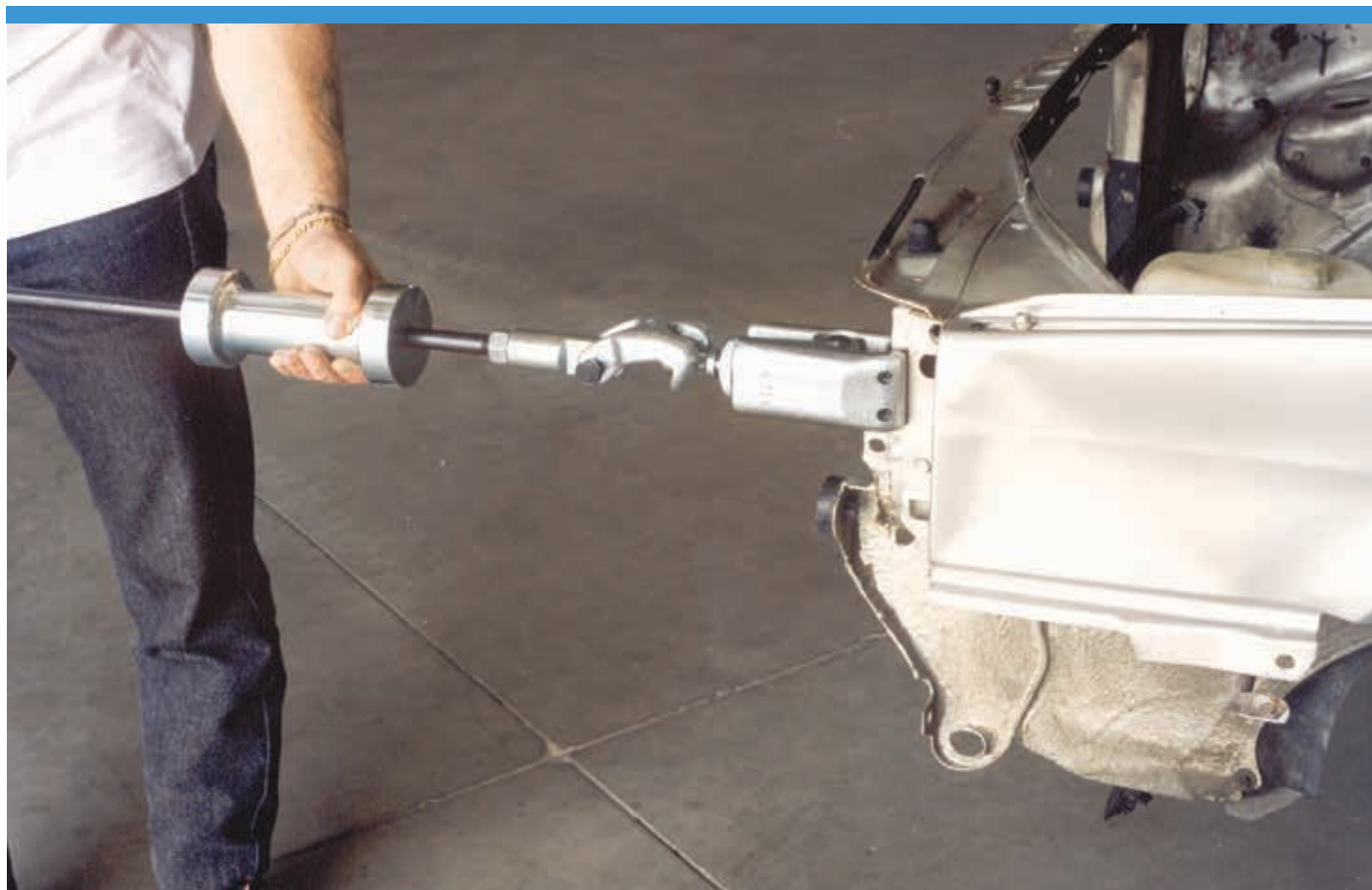

### Art. 200

Questo set composto da un martello di grande potenza (4 kg. di forza battente) e 4 accessori di tiro, permette di effettuare piccole ma efficaci riparazioni, senza dover utilizzare il braccio idraulico di tiro.

Per le sue dimensioni ridotte e la sua efficacia è uno strumento di grande utilità per i carri attrezzi e i servizi di soccorso stradale, oltre che per lavori di sgrassatura in carrozzeria.

This set consists of a powerful slide hammer (4 kg of beating force) and 4 pull accessories. It is suitable for small but effective repairs without having to use the hydraulic arm.

Because of its compact size and effectiveness, this is a very useful tool for breakdown vans and road assistance services, besides being indispensable in every panel beater shop.



## KIT MARTELLO DI TIRO | SLIDE HAMMER SET Art. 200

### Applicazioni | Use mode



Caratteristiche tecniche Technical specifications		200
Materiale Material		acciaio steel
Massa Battente Sliding weight	Kg	4
Lunghezza del martello completo di gancio Length of slide hammer complete with pull claw	mm	920
Peso Weight	Kg	13,8



Art. 201 | Martello di tiro 4 kg con manina  
Slide hammer 4 kg



Art. 202 | Morsetto autobloccante speciale  
Special self locking pull clamp



Art. 203 | Perno sagomato  
Special profil hook



Art. 204 | Coppia angolari di tiro  
Pair of angle pieces

Tutti i componenti del Set art. 200 possono essere forniti anche singolarmente secondo i numeri di riferimento indicati.

All set components are available as single pieces, according to the reference numbers indicated.

### Prodotti correlati | Related products



Art. 205 | Martello di tiro 7kg.  
Slide hammer 7 kg.



Art. 211 | Kit Ganci  
Hooks kit





## MARTELLLO DI TIRO HD | HD SLIDE HAMMER Art. 205

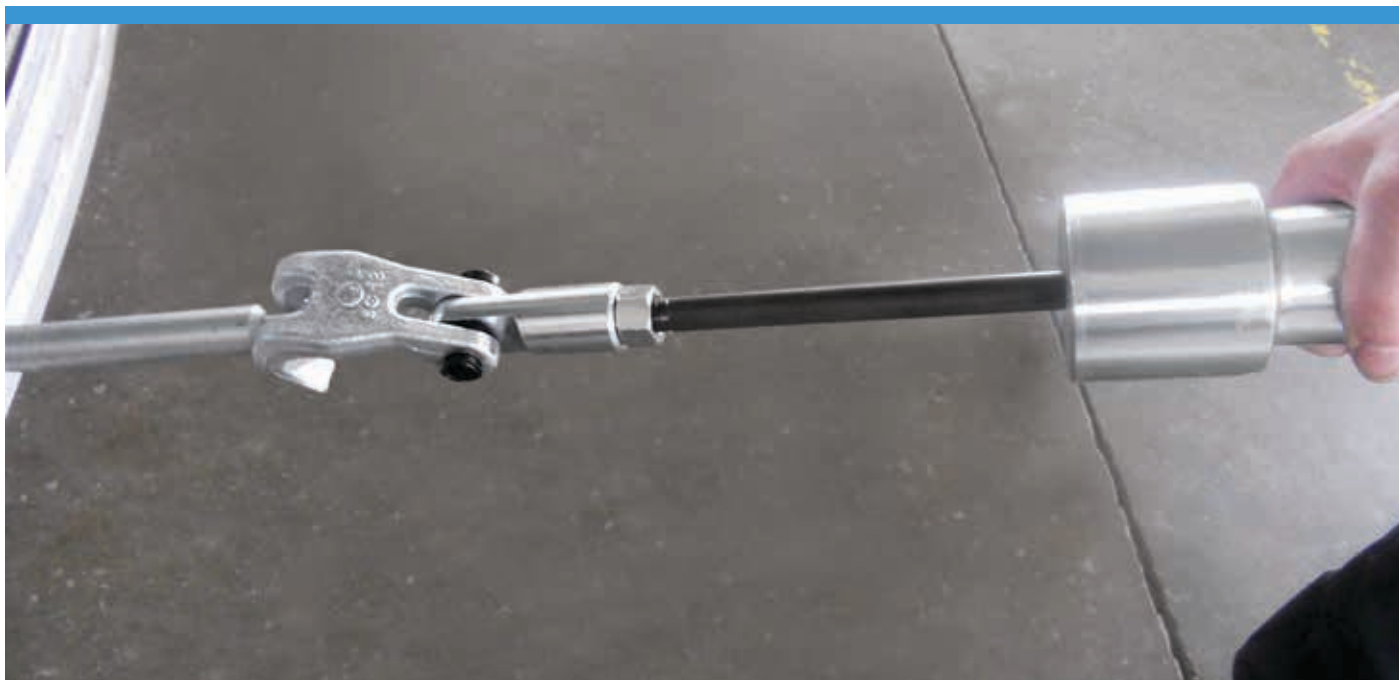

**Art. 205**  
Martello di tiro per impieghi pesanti.  
Questo martello di grande potenza, dotato di massa battente di 7 kg, permette di eseguire efficacemente operazioni di tiro, senza l'impiego di attrezzatura idraulica. Viene impiegato da solo, oppure unitamente agli accessori art. 202, art. 203 art. 204.  
E' un corredo ideale per ogni carrozzeria e per i servizi di soccorso stradale.

**Heavy Duty Slide hammer 7 kg.**  
This high-power hammer features a sliding weight of 7 kg and successfully permits pulling operations without the use of hydraulic equipment. It can be used alone or together with accessories item 202, 203, 204. An important tool for any bodywork shop and vehicle breakdown service.

### Prodotti correlati | Related products



Art. 202 | Morsetto autobloccante speciale  
Special self locking pull clamp



Art. 203 | Perno sagomato  
Special profil hook

Esempio di impiego unitamente al morsetto art. 202 (optional).

Example of use with pull clamp item 202 (optional).



Art. 204 | Coppia angolari di tiro  
Pair of angle pieces



## MARTELLINO DI TIRO HD | HD SLIDE HAMMER Art. 205



Caratteristiche tecniche Technical specifications		205
Materiale Material		acciaio steel
Massa Battente Sliding weight	Kg	7
Lunghezza del martello completo di gancio Length of slide hammer complete with pull claw	mm	920
Peso Weight	Kg	9,4



## MARTELLINO DI TIRO "THOR" | "THOR" SLIDE HAMMER Art. 206



### Art. 206

Martello di tiro per impieghi pesanti.

Questo martello di grande potenza, dotato di massa battente di 9 kg, permette di eseguire efficacemente operazioni di tiro, senza l'impiego di attrezzatura idraulica. E' un corredo ideale per ogni carrozzeria e per i servizi di soccorso stradale. Dotato di un gancio a manina.

Heavy Duty Slide hammer.

This high-power hammer features a sliding weight of 9 kg and successfully permits pulling operations without the use of hydraulic equipment. For any bodywork shop and vehicle breakdown service. Equipped with a little hand hook.

Caratteristiche tecniche Technical specifications		206
Materiale Material		acciaio steel
Massa Battente Sliding weight	Kg	9
Lunghezza del martello completo di gancio Length of slide hammer complete with pull claw	mm	920
Peso Weight	Kg	11,30

### Prodotti correlati | Related products



Esempio di impiego unitamente al morsetto Art. 202 (optional).  
Example of use with pull clamp Item 202 (optional).



Art. 202 | Morsetto autobloccante speciale  
Special self locking pull clamp



Art. 203 | Perno sagomato  
Special profil hook



Art. 204 | Coppia angolari di tiro  
Pair of angle pieces

### Accessori | Accessories



Art. 207 | Kit ganci. Comprende 3 ganci e un adattatore per martello M.16  
Hooks kit. Includes 3 hooks and 1 adapter M.16 for hammer





## MARTELLI DI TIRO "THOR3" | "THOR3" SLIDE HAMMER Art. 206/S



### Art. 206/S

Martello di tiro per impieghi pesanti.

Questo martello di grande potenza, dotato di massa battente di 9 kg, permette di eseguire efficacemente operazioni di tiro, senza l'impiego di attrezzatura idraulica.

E' un corredo ideale per ogni carrozzeria e per i servizi di soccorso stradale. Dotato di 3 ganci.

### Heavy Duty Slide hammer.

This high-power hammer features a sliding weight of 9 kg and successfully permits pulling operations without the use of hydraulic equipment.

For any bodywork shop and vehicle breakdown service. Equipped with 3 hooks.

Caratteristiche tecniche Technical specifications		206/S
Materiale Material		acciaio steel
Massa Battente Sliding weight	Kg	9
Lunghezza del martello completo di gancio Length of slide hammer complete with pull claw	mm	920
Peso Weight	Kg	12,40

### Kit ganci | Hooks kit Art. 211



Comprende 7 ganci e un adattatore per martello M.16. E' abbinabile ai martelli Art. 201 e/o 205  
Includes 7 hooks and 1 M.16 adapter for hammer. It can be used together with Item 201 and/or 205

### Accessori | Accessories



Art. 06100100 | Kit supporto manina M.16  
M.16 claw kit



## KIT MARTELLO + GANCI DI TIRO | SET SLIDE HAMMER + HOOKS Art. 210



### Art. 210

#### Kit Martello + ganci di tiro - 9 accessori

Questo kit contiene un martello con massa battente di 4 kg e 8 diversi tipi di ganci e attacchi, che vanno applicati direttamente sul lamierato danneggiato.

I ganci senza il martello sono disponibili anche come kit singolo (art. 211) per essere utilizzati unitamente al martello art. 201 e/o 205.

#### Set Slide hammer + hooks - 9 accessories

This kit contains a hammer with sliding weight of 4 kg and 8 different types of hooks and fasteners to be fitted directly to the damaged parts.

The hooks without the hammer are also available as a single kit (item 211) to be used together with hammer item 201 and/or 205.

Caratteristiche tecniche Technical specifications		210
Materiale Material		acciaio steel
Massa Battente Sliding weight	Kg	4
Lunghezza del martello senza gancio Length of slide hammer without pull hook	mm	770
Peso Weight	Kg	9,7

## Kit ganci | Hooks kit Art. 211



Comprende 7 ganci e 1 adattatore M.16 per martello.  
E' abbinabile ai martelli art. 201 e/o 205

Hooks kit includes 7 hooks and 1 M.16 adapter for hammer.  
It can be used together with item 201 and/or 205.



## KIT MARTELLI IN ALLUMINIO | KIT ALUMINIUM HAMMERS Art. 215 e 219



### Art. 215

Il kit martello in alluminio viene utilizzato per ammaccature su particolari di carrozzeria. Le testine intercambiabili possono essere sostituite con estrema rapidità a seconda del tipo di lavoro che si deve svolgere.

The aluminum hammer is used on minor car body dents. The interchangeable heads can be quickly replaced to meet specific work requirements.



### Art. 219

Il kit comprende n° 7 martelli in alluminio di forme diverse

The kit includes 7 aluminium hammers of different shapes

### Art. 215 Dotazione standard | Standard equipment



#### Il kit comprende:

- 1 valigetta in plastica
- 4 testine in alluminio
- 1 testina in acciaio anodizzato
- 1 testina in teflon
- 1 tassello in teflon
- 1 tassello in cuoio
- 1 martello con corpo in alluminio filettato porta testine

#### The kit contains:

- 1 plastic case
- 4 aluminum heads
- 1 anodized steel head
- 1 teflon head
- 1 teflon block
- 1 leather block
- 1 hammer with head-holder threaded aluminum body





## PANNELLO ESPOSITORE A MURO | WALL TOOL PANEL Art. 300

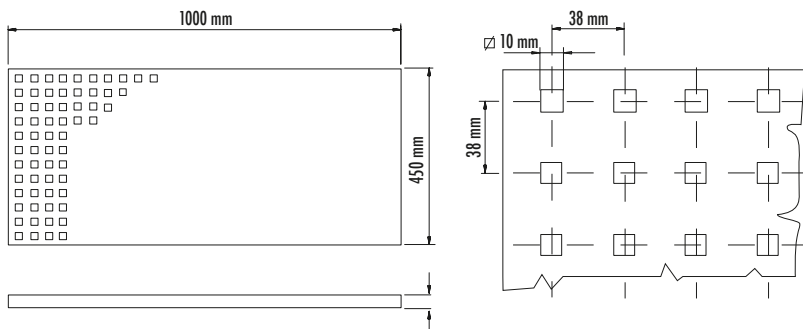
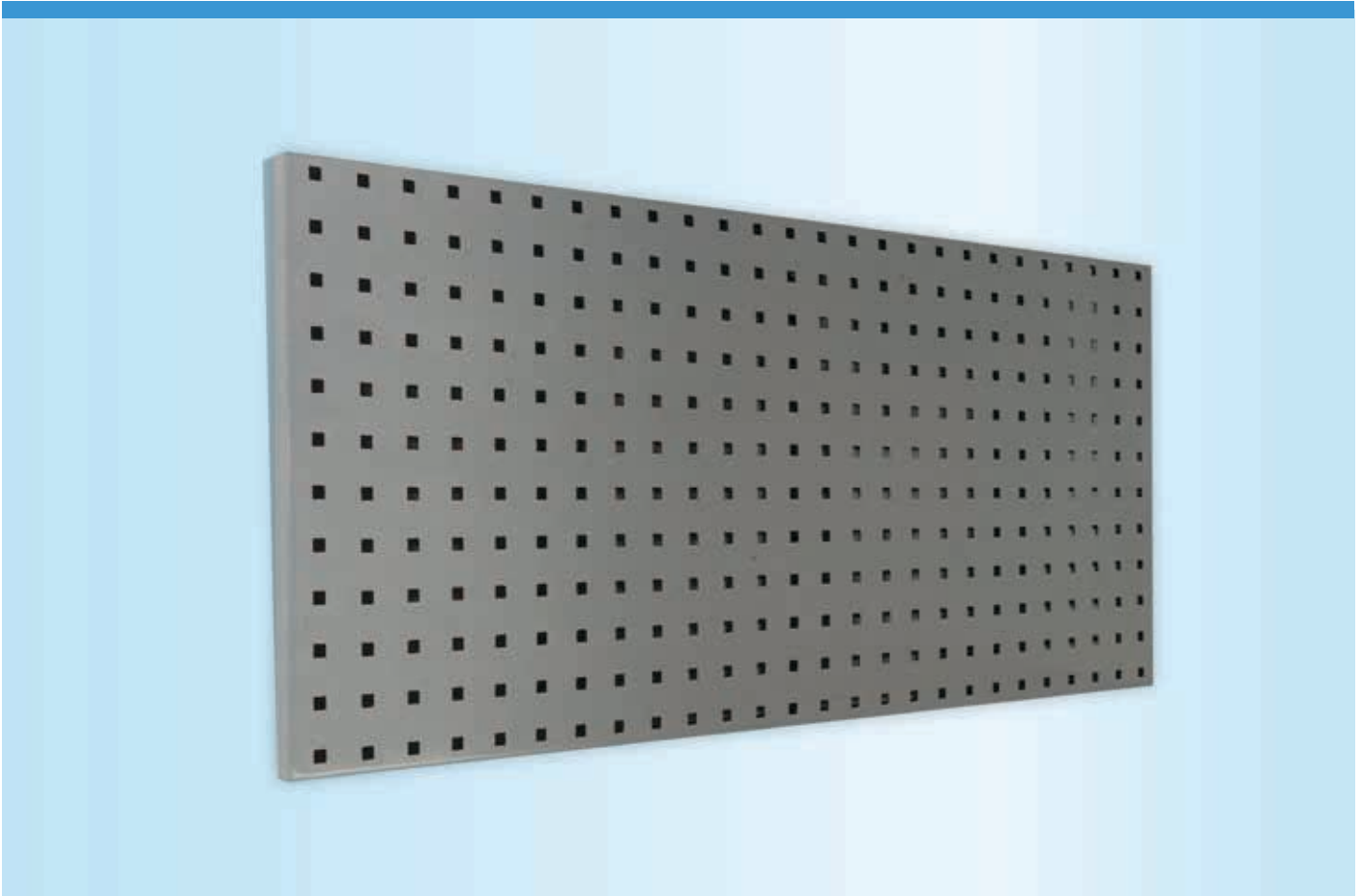

Caratteristiche tecniche Technical specifications		300
Materiale Row Material		ferro iron
Peso Weight	Kg	6,8

### Accessori | Accessories



Art. 06500100 | Gancio semplice  
Simple fixture



Art. 06500200 | Gancio doppio  
Double fixture

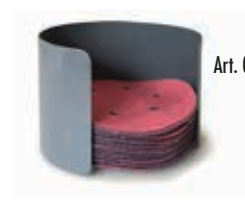

Art. 06501500 | Porta dischi abrasivi  
Container for abrasive discs



## ESPOSITORE A CARRELLO | TOOL TROLLEY Art. 301

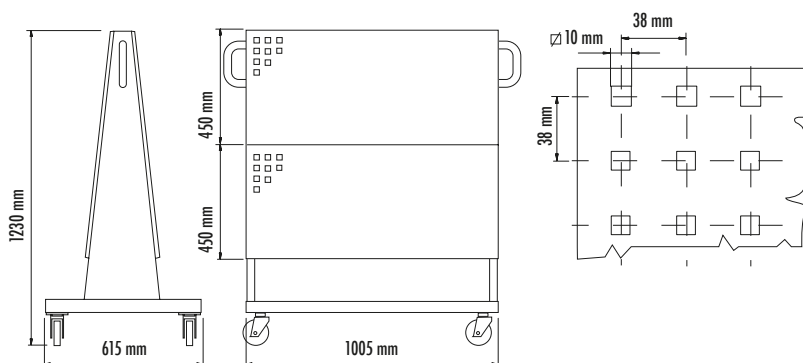

**Art. 301**  
Espositore a carrello. Gli accessori e i ganci fotografati NON sono compresi nelle forniture dell'articolo.

Tool trolley. The accessories and hooks shown in the picture are NOT included in the delivery of the trolley ref.

Caratteristiche tecniche Technical specifications		301
Materiale Raw Material		ferro iron
Peso Weight	Kg	38

### Accessori | Accessories



Art. 06500100 | Gancio semplice  
Simple fixture



Art. 06500200 | Gancio doppio  
Double fixture



## NEW DISC DISPENSER Art. 303R



Art. 06501500



### Art. 303R

di servizio per zona preparazione

- Carrello maneggevole di dimensioni ideali (500 x 700 x 1300 H)
- Pannello a foro quadro con ganci per fissaggio utensili
- 3 postazioni di montaggio e stoccaggio dischi abrasivi
- Piano di lavoro
- 2 ante con serratura di chiusura per stoccaggio materiali
- Vani laterali esterni porta bombolette
- Portarotolo esterno
- Il carrello viene fornito smontato e può essere comodamente stoccato

### Service Trolley for preparation area

- Trolley in big size (500 x 700 x 1300 h) easy to move around
- Back wall with square holes with special hooks for stocking of tools
- 3 adjustable dockin stations for abrasive disks to pneumatic tools
- 2 shelves inside, door with lock
- 2 external side trays for spray bottles
- 1 holder for paper roll
- Trolley delivered dismantled to reduce transport and stocking volume

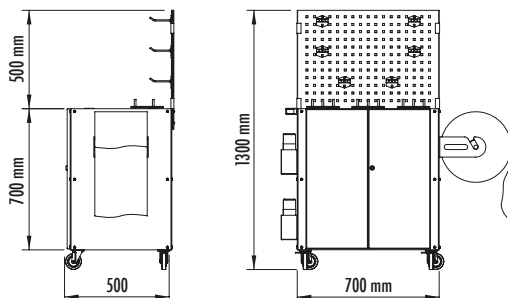

Caratteristiche tecniche Technical specifications		303R
Materiale, Raw Material		acciaio steel
Peso Weight	Kg	60





## CARRELLO PER LAMIERATI | STORAGE TROLLEY Art. 304

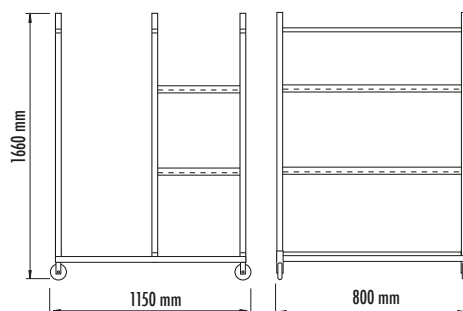

### Art. 304

Pratico carrello per riporre ordinatamente tutto il materiale smontato da una vettura in riparazione.

Robusto e maneggevole, dotato di 2 ruote piroettanti e 2 fisse, consente lo stoccaggio sicuro e razionale delle parti smontate.

Large trolley to stow all parts dismantled from a vehicle before repair.

It is very strong and handy, thanks to 2 swivel wheels: loose parts can be neatly set away and quickly returned to the vehicle for reassembling.

Caratteristiche tecniche Technical specifications	304	
Materiale, Raw Material	tubolare in ferro verniciato tubular painted steel	
Peso Weight	Kg	62



## SGABELLO | STOOL Art. 305

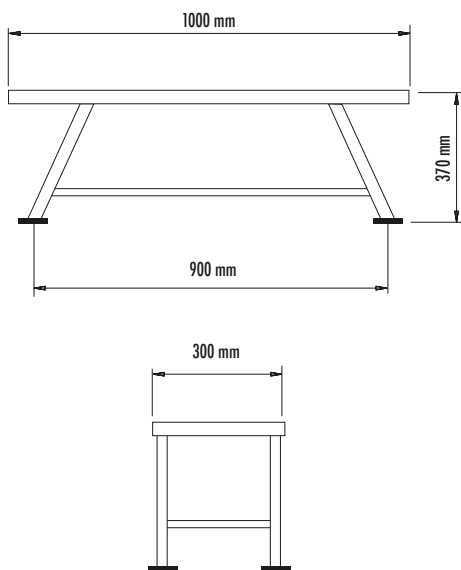

Art. 305  
Sgabello.  
Robusta predella con pianale in legno isolante, completamente smontabile.

Stool.  
Strong platform with wooden top, completely dismantlable.

Caratteristiche tecniche Technical specifications		305
Materiale Raw Material: - struttura structure - piano top		verniciata painted legno wood
Peso Weight	kg	10,6



## PEDANA ALLUMINIO | ALUMINIUM LADDER Art. 305A



### Art. 305A

Pedana in alluminio regolabile in altezza e lunghezza, stabile, facilmente trasportabile.

Aluminium platform, adjustable in height and length, stable, easy to carry.

Caratteristiche tecniche Technical specifications		305A
Materiale Raw Material		alluminio aluminium
Portata max Max lifting capacity	kg	150
Lunghezza min/max Min/max. length	mm	da 1090 a 1750 from 1090 to 1750
Larghezza Width	mm	300
Altezza min/max Max/Min. height	mm	da 522 a 905 from 522 to 905
Approvazione Approval		EN131
Peso Weight	Kg	15





## RASTRELLIERA PER PARAURTI | BUMPERS RACK Art. 308



Art. 308

Rastrelliera per paraurti. Consente lo stoccaggio rapido e razionale di 4 paraurti. La rastrelliera viene fornita completamente smontata.

Bumpers Rack. Strong rack for rational storage of 4 car bumpers. The bumper rack is supplied completely dismantled to reduce transport costs.



## RASTRELLIERA DOPPIA PER PARAURTI | DOUBLE BUMPERS RACK Art. 308D

### Art. 308D

Rastrelliera doppia per paraurti con ruote, consente lo stoccaggio di massimo 8 paraurti. Facilmente dislocabile grazie alle 4 ruote piroettanti. La rastrelliera viene fornita completamente smontata.

Double bumpers rack with castors, for the storage of max 8 car bumpers. Easily moveable thanks to the 4 swivel wheels. The bumper rack is supplied completely dismantled to reduce transport costs.



Caratteristiche tecniche Technical specifications		308	308D
Materiale Raw Material		tubolare verniciato painted tubular steel	tubolare verniciato painted tubular steel
Max capacità stoccaggio Max Storage capacity		4 paraurti 4 car bumpers	8 paraurti 8 car bumpers
Larghezza Jaw width	mm	1090	1090
Altezza Height	mm	2140	2140
Profondità bracci Profondità bracci	mm	500	500
Peso Weight	Kg	28	52



## ROTOFIX Art. 309



### Art. 309

Consente il fissaggio ed il trasporto di lamierati, di diverse forme e dimensioni, in modo sicuro e veloce in fase di preparazione, levigatura o verniciatura, mediante un semplice movimento eseguito da un solo operatore.

Anche i lamierati più pesanti ed ingombranti possono essere bloccati nella posizione voluta facilmente e senza sforzo, grazie al dispositivo di fermo composto da corona dentata e pedale.

Grazie alla prolunga svitabile ed agli speciali supporti, possono venire fissati contemporaneamente sul ROTOFIX anche due paraurti di grandi dimensioni. L'attrezzo è dotato di due ruote in gomma per poter essere facilmente spostato.

Allows you to fasten steel sheet panels of varying shapes and sizes safely and quickly, and also to handle them during preparation, sanding or painting by means of a simple movement performed by a single operator.

Thanks to the special locking device by means of crown wheel and pedal even large and heavy metal panels can be blocked in the desired position.

Thanks to the removable extension and the special supports, even two large-size bumpers can be attached to ROTOFIX, at the same time.

The unit which is provided with two rubber wheels for easy movement.





## ROTOFIX Art. 309

### Applicazioni | Use mode



Caratteristiche tecniche Technical specifications		309
Materiale Raw Material		tubolare verniciato, painted tubular steel
Peso Weight	kg	29

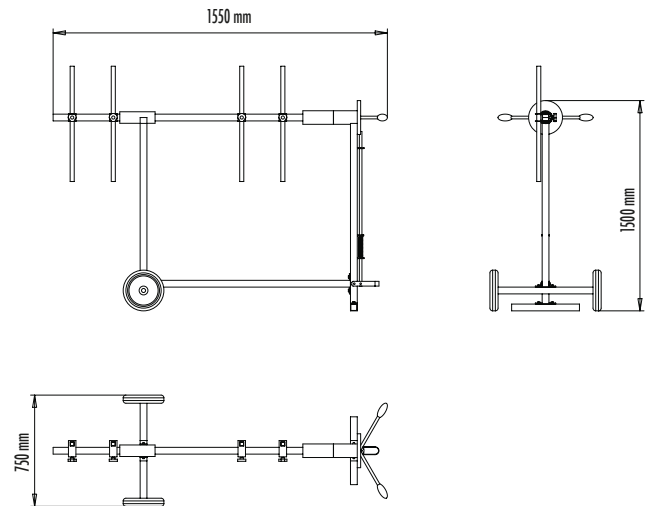



## CARRELLO SALVASPAZIO | COMPACT TROLLEY Art. 309A



### Art. 309A

Consente il fissaggio ed il trasporto di lamierati, di diverse forme e dimensioni, in modo sicuro e veloce grazie ai suoi supporti speciali. Ideale nelle fasi di preparazione, levigatura o verniciatura degli stessi. Quando viene rispinto può essere velocemente richiuso occupando uno spazio minimo.

For securing and transporting sheet metal parts of various sizes and shapes, safety and quickly thanks to its special supports. Ideal for preparing, rubbing down or coating parts. Folds down to occupy minimal space when not in use.



## CARRELLO SALVASPAZIO | COMPACT TROLLEY Art. 309A

### Applicazioni | Use mode



Caratteristiche tecniche Technical specifications		309A
Materiale Raw Material		tubolare acciaio zincato galvanized tubular steel
Peso Weight	kg	16,50

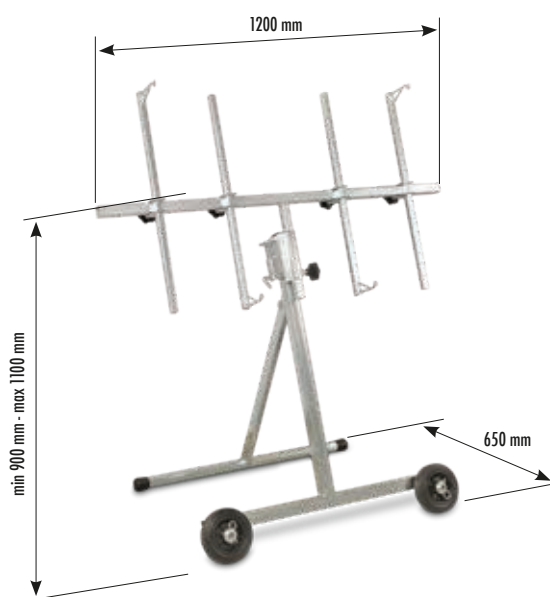

### Accessori | Accessories

Art. 07503500

Kit bracci mobili per 309A. Con l'utilizzo/abbinamento di questo kit il carrello 309A può essere impiegato anche per bloccare saldamente cover e paraurti con spessori sottilissimi e pertanto facilmente deformabili nelle varie fasi di lavorazione.

Movable arms kit for 309A. With the use/combination of this kit, the trolley 309A can also be used to firmly hold in place covers and bumpers that are very thin and therefore easy to deform while working.







## RONNY Art. 309C



### Art. 309C

Il carrello 309C, utilizzando gli opportuni sistemi, consente di bloccare saldamente cerchi e cofani di autovetture nelle varie fasi di lavorazione. E' utilizzabile in tutte le operazioni di preparazione, verniciatura e asciugatura.

Il 309C ha ingombri ridottissimi, è orientabile in tutte le posizioni e scorre perfettamente sui grigliati delle cabine di verniciatura.

The 309C trolley allows you to firmly lock car rims and bonnets (using the appropriate systems) during the various processing stages. It can be used in all preparations, painting and drying operations.

The 309C trolley is extremely compact, can be oriented in any position and runs perfectly on the painting booth grids.



## RONNY Art. 309C

### Applicazioni | Use mode



Caratteristiche tecniche Technical specifications		309C
Materiale Row Material		ferro zincato bianco white zinc plated iron
Peso Weight	kg	29



### Accessori | Accessories



Art. 06500800 | Kit 4 coni per cerchi  
Kit 4 cones for car rims



Art. 06500850 | Kit 4 coni per cerchi con supporti asolati  
Kit 4 cones and supports for car rims

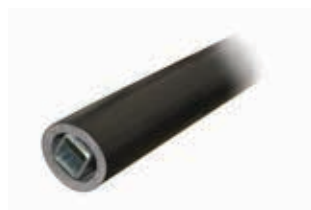

Art. 06502000 | Kit protezione bracci (4pz)  
Kit protection arms (4pcs)



## CARRELLO PORTA-PARAURTI | BUMPER STAND Art. 309V



### Art. 309V

Il carrello 309V consente di bloccare saldamente cover e paraurti di autovetture di spessori sottilissimi, e pertanto facilmente deformabili, nelle varie fasi di lavorazione. E' utilizzabile in tutte le operazioni di preparazione, verniciatura e asciugatura.

Il 309V ha ingombri ridottissimi, è orientabile in tutte le posizioni e scorre perfettamente sui grigliati delle cabine di verniciatura.

The mobile stand 309V allows secure fastening of car covers and bumpers in very thin thickness, and therefore easily deformable, in the various working phases. It can be used in all preparation, painting and drying operations.

309V has very compact dimensions, is adjustable in all positions and runs perfectly on grid floors inside paint booths.







## CARRELLO PORTA-PARAURTI | BUMPER STAND Art. 309V

### Applicazioni | Use mode



Art. 309V + Art. 07503300

Caratteristiche tecniche Technical specifications		309V
Materiale Raw Material		tubolare verniciato painted tubular steel
Peso Weight	kg	19

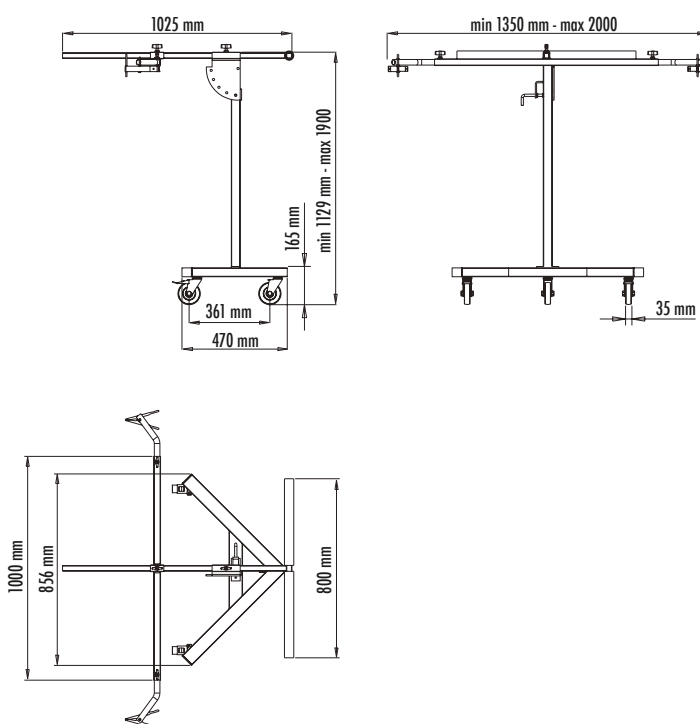

### Accessori | Accessories



Art. 07503300

Il kit bracci mobili forniti optional consente l'utilizzo del carrello 309V anche per lavorazioni su lamierati vari e parafranghi.  
Kit of dismantlable arms, supplied optional upon request, makes the 309V suitable for fastening various sheets and fenders as well, for greater versatility.



Art. 07601000

Kit di 3 ruote (2 con freno e una senza) Ø 125 mm  
Kit of 3 wheels (2 wheels with brake and one without) Ø 125 mm

### Prodotti correlati | Related products



Art. 463

Doppia morsa magnetica  
Magnetic double clamp



## PORTALIGHT Art. 311



Carrello di servizio utilizzabile per smontaggio/montaggio di sportelli pesanti anche di grandi dimensioni. Robusto, preciso, facilmente trasportabile, è dotato di supporti portalamierati rivestiti in gomma, e di ruote frenanti per evitare movimenti durante le fasi di lavoro. La particolare stabilità lo rende indicato anche per operazioni di saldatura di cerniere al nuovo pezzo o sostituzione di montanti.

Door Service Trolley for fast, precise and easy replacement of heavy and cumbersome doors.

Very stable and precise, it is equipped with special rubber support coverings to prevent damage to freshly-painted metal surfaces. Easily moveable and steady thanks to the castors, which feature brakes. PORTALIGHT is very useful in the event of replacement of the pillars and of hinges having to be welded onto the new pieces.



## PORTALIGHT Art. 311

### Applicazioni | Use mode



Caratteristiche tecniche Technical specifications		311
Materiale Raw Material		acciaio verniciato a polvere powder coated steel
Altezza max portiere Max door height	mm	2600
Portata Lifting capacity	Kg	60
Imballo Packaging	mm	1 scatola cartone 1160x850x50 1 scatola cartone 1330x330x290 1 cardboard box 1160x850x50 1 cardboard box 1330x330x290
Peso Weight	Kg	41

### Dimensioni di lavoro Working sizes

Dimensioni minime sportelli Minimum size doors	mm	700
Dimensioni massime sportelli Maximum size doors	mm	2600
Altezza minima di montaggio da terra Minimum height from floor	mm	200
Altezza massima di montaggio da terra Maximum height from floor	mm	900

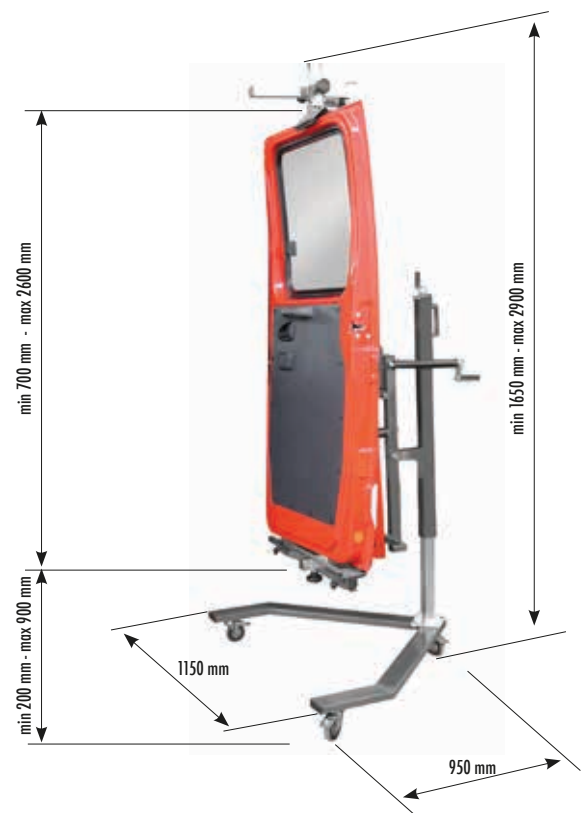





## RASTRELLIERA VERTICALE | VERTICAL RACK Art. 313



### Art. 313

#### Rastrelliera verticale.

Consente lo stoccaggio rapido e razionale dei parabrezza. I bracci portanti sono rivestiti di morbida gomma. Solo per uso singolo, senza ruote.

La rastrelliera viene fornita completamente smontata.

#### Vertical rack.

Strong rack for rational storage of car windscreen. The supporting arms are covered with soft foam protection. To be used single without castors.

The bumper rack is supplied completely dismantled to reduce transport costs.

Caratteristiche tecniche Technical specifications		313
Materiale Raw Material		tubolare verniciato con protezione gommapiuma tubular painted steel, with foam protections
Max capacità stoccaggio Max Storage capacity		4 parabrezza 4 windscreens
Larghezza Jaw width	mm	1090
Altezza Height	mm	2140
Profondità bracci Profondità bracci	mm	1000
Peso Weight	Kg	42,2





## CART ROLLER Art. 317



Art. 317  
Carrello sbobinatore per carta e teli da mascheratura. Carrello in acciaio verniciato, dotato di 5 supporti per rotoli di carta da mascheratura, completi di lame in acciaio dentate per il taglio netto della carta. Il carrello 317 è stato studiato per supportare bobine con le seguenti lunghezze: 100 - 300 - 450 - 650 - 850 - 1000 - **1200** mm.  
E' dotato di 2 ruote. Viene fornito smontato in due parti, senza carta per mascheratura.

Dereeler trolley for paper and masking web. Trolley in painted steel, fitted with 5 supports for rolls of masking paper, complete with toothed steel blades for cutting the paper. The trolley 317 is designed to hold rolls of the following lengths: 100 - 300 - 450 - 650 - 850 - 1000 - **1200** mm.  
Equipped with 2 wheels. Supplied disassembled in two parts, without masking paper.





## CART ROLLER Art. 317

### Applicazioni | Use mode



Caratteristiche tecniche Technical specifications		317
Materiale Raw Material		acciaio verniciato steel pulver painted
N. Posizioni bobine N. Position rolls		5
Peso Weight	Kg	32

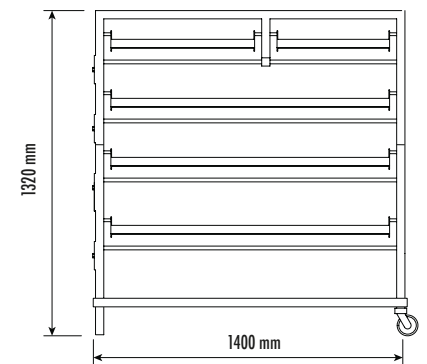
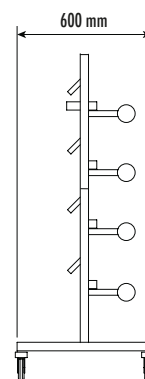

**Nota:**  
carrello fornito montato ma con struttura in tre parti.

**Note:**  
trolley supplied assembled but with the structure in three parts.



## CARRELLO ESTENSIBILE | TELESCOPIC TROLLEY Art. 318



Art. 318  
Carrello Estensibile.  
Grazie al meccanismo "a fisarmonica", questo carrello può essere adattato in lunghezza alle dimensioni di tutti i lamierati e dei paraurti, anche se notevolmente differenti fra loro. I bracci di appoggio sono protetti da speciali rivestimenti in materiale morbido e sono regolabili in altezza.

Telescopic Trolley.  
Thanks to the "accordion" mechanism, this trolley can be adapted in terms of length to the dimensions of all metal sections and bumper-bars, even when the difference between these is considerable.  
The support arms are protected by a special softmaterial covering and are height adjustable.



## CARRELLO ESTENSIBILE | TELESCOPIC TROLLEY Art. 318

### Applicazioni | Use mode



Caratteristiche tecniche Technical specifications		318
Materiale Raw Material		acciaio verniciato e zincato painted steel and galvanized
Lunghezza min (chiuso) Min. length (closed)	mm	240
Lunghezza max Max length	mm	1415
Peso Weight	Kg	23
Portata max Max capacity	Kg	180

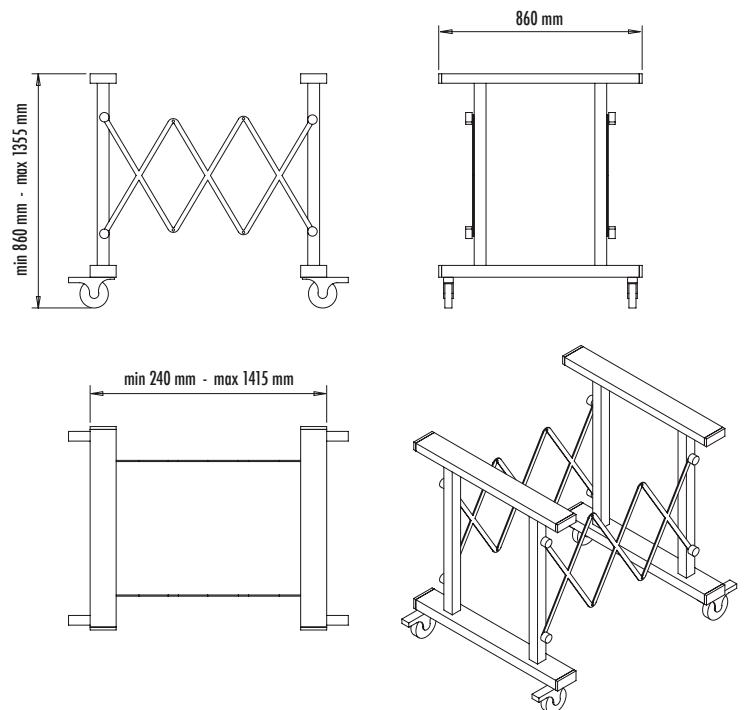





## METRO TELESCOPICO | TELESCOPIC TRAM GAUGE Art. 400

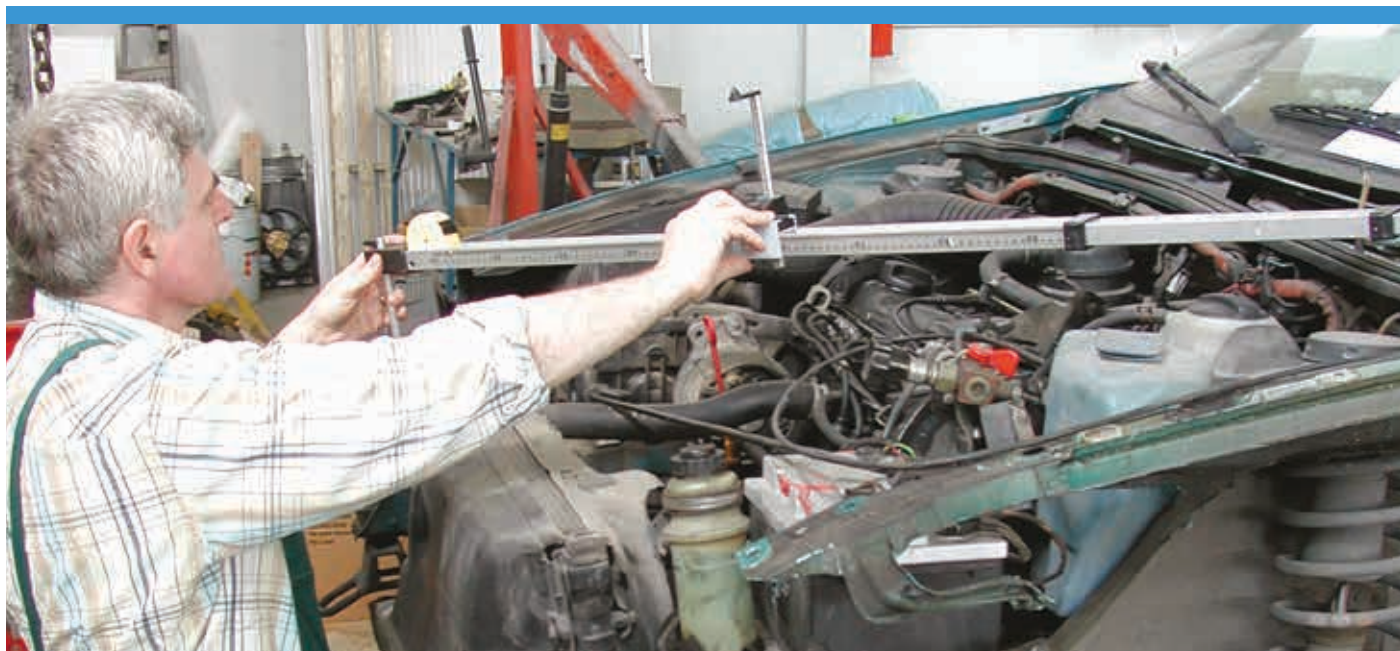

### Art. 400

Con il Metro Telescopico è possibile effettuare con facilità e precisione le seguenti operazioni:

- squadrature dell'automezzo
- controllo passo ruote
- bombatura delle parti sagomate
- riscontro di deformazioni sui vani porta/motore e parti vetrate.

Il metro telescopico rimane perfettamente in asse anche se totalmente aperto.

With the Telescopic Tram Gauge it is easy to carry out the following operations with the maximum precision:

- squaring of vehicle
- wheelbase checks
- flaring of shaped parts
- checking deformations in the door and engine compartments and window frames.

The Telescopic Tram Gauge remains perfectly aligned even when fully opened.



## Accessori | Accessories



Art. C1100100 | Livella  
Level



Art. D4080100  
Ø20



Art. D4080200  
Ø30

Punte in alluminio per centraggio di precisione su fori sotto scocca  
Aluminium points for precision centering on underbody



Art. D5054500 | Perno speciale L. 450mm  
Special stud L. 450mm



## METRO TELESCOPICO | TELESCOPIC TRAM GAUGE Art. 400

### Applicazioni | Use mode



Caratteristiche tecniche Technical specifications		400
Materiale Material		metro in alluminio satinato e in poliammide aluminium satin and polyamide tram gauge
Lunghezza minima attrezzo chiuso Minimum length closed	mm	1050
Lunghezza massima attrezzo aperto Maximum length open	mm	2995
Lunghezza perni Pin length	mm	2 perni da 290 mm 1 perno da 90 mm 2 pins measuring 290 mm 1 pin measuring 190mm
Peso Weight	Kg	1,6



Letture facilitate delle misurazioni eseguite grazie al metro avvolgibile visibile attraverso il vetrino.

Instant read out of measurements on the yellow tape measure through the window.

Leggero e preciso richiede un solo operatore; ogni sezione può essere bloccata in posizione, quando totalmente o parzialmente estesa.

Lightweight and precise, for one-man operation, as each section is lockable when fully or partially extended.



## STRISCIA MAGNETICA | MAGNETIC STRIPS Art. 570



### Dotazione standard | Standard equipment

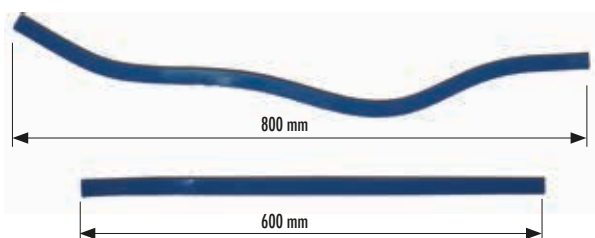

#### Art. 570

Queste strisce magnetiche sono estremamente flessibili e quindi applicabili a qualsiasi tipo di lamierato.

Sono indispensabili per:

- ridisegnare profilo originale di modanature curve e /o diritte, prima di procedere alla riparazione di lamierati mediante spotter
- sostituire la carta gommata nella riprofilatura post stuccatura, garantendo velocità, precisione e risparmio di materiali di consumo
- delimitare area di lavoro della levigatrice orbitante; proteggere area circostante alla zona di lavoro

These magnetic strips are very flexible and therefore applicable to any type of panel sheets.

The magnetic strips are essential for:

- redesign original profile of curved and / or straight moldings, before proceeding to dent repair by means of spotter
- Replace gummed paper in the reprofiling by means of grinding after filling, ensuring speed, accuracy and consumables savings
- Define the work area of the orbiting sander; protect the panel sheet space surrounding the work area

### Applicazioni | Use mode







## STRISCIA MAGNETICA | MAGNETIC STRIPS Art. 570

Esempio di riprofilatura della modanatura originale | Example of reprofiling of original mouldings

Fase | Step 1



Applicare lo stucco  
Apply filler

Fase | Step 2



Applicare la striscia magnetica seguendo il profilo originale e tracciare un linea di lavoro con la matita  
Apply magnetic strip along the original profile and sign a working line by pencil

Fase | Step 3



La zona da levigare e profilare è chiaramente e velocemente segnata  
Working area is clearly and quickly indicated by a secure pencil sign

Fase | Step 4



Levigatura e riprofilatura del lamierato  
Grinding and reprofiling of panel sheet



## KIT CINGHIE DI TIRO | PULL STRAP KIT Art. 900



### Art. 900

#### Kit cinghie di tiro.

Queste cinghie sostituiscono in molti casi le catene in acciaio e offrono medesima resistenza di tiro delle catene in acciaio specifiche per carrozzeria.

Il tessuto in poliestere, robusto flessibile al tempo stesso, può essere applicato per il tiro in tutte le posizioni della carrozzeria, senza mai danneggiarla. Le cinghie possono venire utilizzate con la massima sicurezza anche su parti meccaniche particolarmente delicate, come le teste degli ammortizzatori.

Peso ed ingombro molto limitato ne rendono l'utilizzo continuato particolarmente agile per l'operatore.

In caso di rottura dovuta a potenza di tiro superiore a quella consentita, non possono causare danni irreparabili a persone o cose.

#### Pull strap kit.

These pull straps in double polyester with reinforced eyelets replace traditional steel chains in many cases and offer same pull strength as steel chains specific for bodywork. The tough and at the same time flexible polyester fabric can be fitted for pulling operations in all bodywork positions without its ever being damaged. The strap can be used with total confidence even on particularly delicate mechanical parts, such as shock absorber heads, for straightening operations.

Limited weight and dimensions make the straps particularly easy to handle and used.

In the event of failure caused by pull force in excess of the permitted limit, the belts will not cause irreparable damage to persons or things.

## Dotazione standard | Standard equipment

Confezione in valigetta da 3 pezzi:

- 1 cinghia (L 800 mm x H 60 mm)
- 1 cinghia (L 1200 mm x H 60 mm)
- 1 cinghia (L 1600 mm x H 60 mm)
- 3 protezioni scorrevoli (L 300 mm)

Portata di tiro 7 ton in linea diretta, 14 ton se applicato ad "U"

Pack in 3 pieces case:

- 1 strap (L 800 mm x H 60 mm)
- 1 strap (L 1200 mm x H 60 mm)
- 1 strap (L 1600 mm x H 60 mm)
- 3 sliding covers (L 300 mm)

Pull capacity 7 ton straight line, 14 ton when used with "U" shape



## FUNE DI TIRO | PULL RING Art. 901

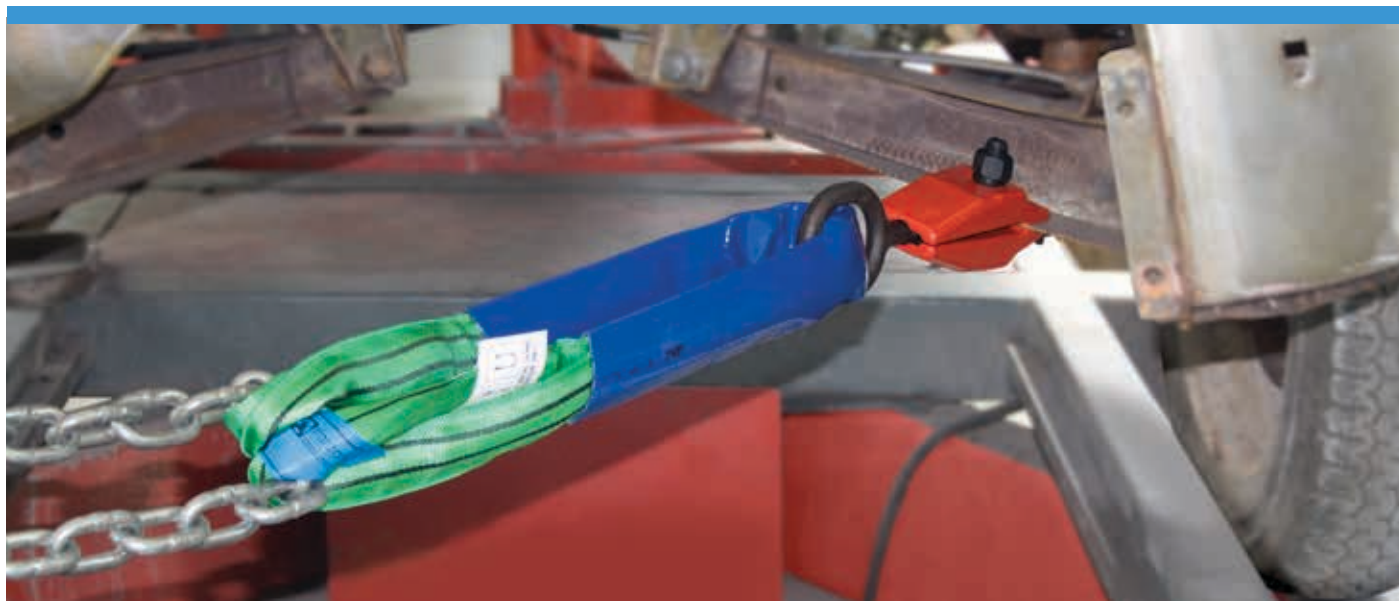

### Art. 901

Fune tubolare in poliestere per inserimento in posizioni di difficile accesso, inguainata con tessuto di protezione.

Shaped tubular rope in polyester can be used in positions affording limited access, with protective fabric sheath.

Caratteristiche tecniche Technical specifications		901
Materiale Material		poliestere polyester
Lunghezza totale Total Length	mm	1000
Diametro Diameter	mm	45
Portata di tiro Pull capacity	ton	Portata di tiro 7 ton in linea diretta, 14 ton se applicato ad "U" Pull capacity 7 ton straight line, 14 ton when used with "U" shape

## Prodotti correlati | Related products



### Art. 903

Tiracinghie. In fase di tiro, le estremità della cinghia lavorano in parallelo. Evita la lacerazione degli occhielli, aumentando quindi la durata delle cinghie.

Shackle. During pulling the strap ends are working perfectly parallel. It prevents eyelet damage, normally caused by chains, thus increasing strap life.

Caratteristiche tecniche Technical specifications		903
Materiale Material		acciaio steel
Peso Weight	kg	3,3





## KIT CINGHIE PER TIRO PESANTE | PULL STRAP KIT FOR HEAVY PULLING Art. 908



### Art. 908

Kit cinghie per tiro pesante.

Queste cinghie sostituiscono in molti casi le catene in acciaio e offrono medesima resistenza di tiro delle catene in acciaio specifiche per carrozzeria.

Il tessuto in poliestere, robusto flessibile al tempo stesso, può essere applicato per il tiro in tutte le posizioni della carrozzeria, senza mai danneggiarla. Le cinghie possono venire utilizzate con la massima sicurezza anche su parti meccaniche particolarmente delicate, come le teste degli ammortizzatori. Peso ed ingombro molto limitato ne rendono l'utilizzo continuato particolarmente agile per l'operatore. In caso di rottura dovuta a potenza di tiro superiore a quella consentita, non possono causare danni irreparabili a persone o cose.

### Pull strap kit for heavy pulling.

These pull straps in double polyester with reinforced eyelets replace traditional steel chains in many cases and offer same pull strength as steel chains specific for bodywork. The tough and at the same time flexible polyester fabric can be fitted for pulling operations in all bodywork positions without its ever being damaged. The strap can be used with total confidence even on particularly delicate mechanical parts, such as shock absorber heads, for straightening operations.

Limited weight and dimensions make the straps particularly easy to handle and used.

In the event of failure caused by pull force in excess of the permitted limit, the belts will not cause irreparable damage to persons or things.

## Dotazione standard | Standard equipment

Il kit da 2 pezzi, confezionati in valigetta contiene:

- 1 cinghia (L 1500 mm x H 80 mm)
- 1 cinghia (L 2500 mm x H 80 mm)
- Protezione ad anello
- Portata di tiro 14 ton in linea diretta, 28 ton se applicato ad "U"

The 2 piece kit, supplied in a case, contains:

- 1 strap (L 1500 mm x H 80 mm)
- 1 strap (L 2500 mm x H 80 mm)
- Ring protection
- Pull capacity 14 ton straight line, 28 ton when used with "U" shape



## CATENE | CHAINS Art. 1500÷3000

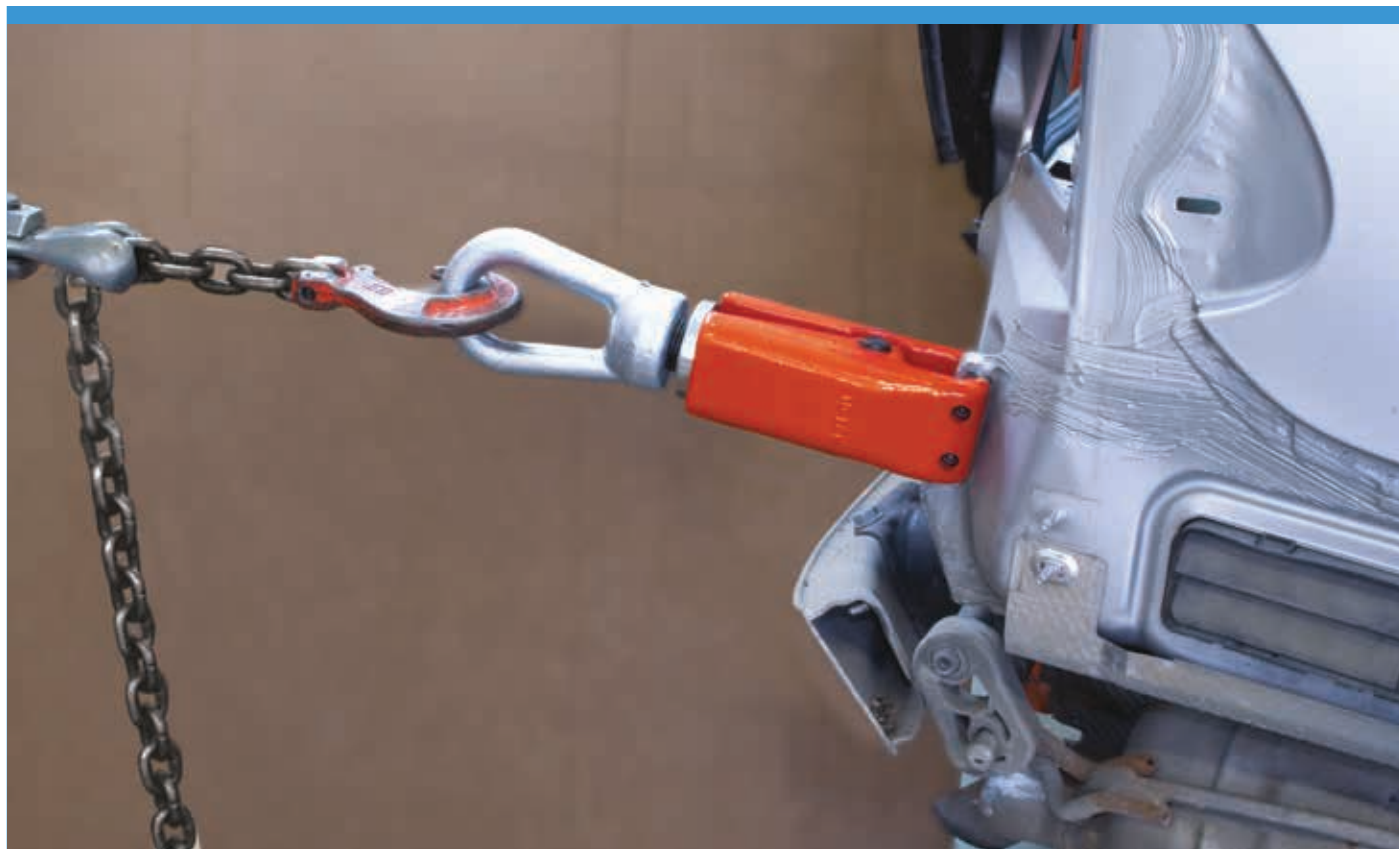

### Art. 1500÷3000

Catene di tiro, zincate elettrosaldate diametro 10mm, disponibili sia con che senza ganci.

Pull chains, zink-plated, electro-welded, diameter 10 mm, available with or without hooks.

Caratteristiche tecniche Technical specifications		1500÷3000
Misura catena Chain size	mm	10
Portata verticale Vertical WLL	ton	3,15
Carico di prova Proof Load	kN	78,5
Carico di rottura minimo garantito M.B.L.	kN	126
Materiale e grado Material and grade		Acciaio legato Gr 80 Gr 80 alloy steel
Coefficiente di sicurezza Safety factor		4
Norme armonizzate applicate Harmonized standard applied		EN 818-2

I carichi minimi indicati sono stati raggiunti o superati  
The specified minimum breaking force is met or exceeded



## CATENE | CHAINS Art. 1500÷3000



Art. 1500	1500 mm
Art. 2000	2000 mm
Art. 2500	2500 mm
Art. 3000	3000 mm



Art. 1501S	1500 mm, 1 gancio/hook
Art. 2001S	2000 mm, 1 gancio/hook
Art. 2501S	2500 mm, 1 gancio/hook
Art. 3001S	3000 mm, 1 gancio/hook



Art. 1502S	1500 mm, 2 ganci/hooks
Art. 2002S	2000 mm, 2 ganci/hooks
Art. 2502S	2500 mm, 2 ganci/hooks
Art. 3002S	3000 mm, 2 ganci/hooks



Art. 1501M	1500 mm, 1 gancio manina/claw
Art. 2001M	2000 mm, 1 gancio manina/claw
Art. 2501M	2500 mm, 1 gancio manina/claw
Art. 3001M	3000 mm, 1 gancio manina/claw

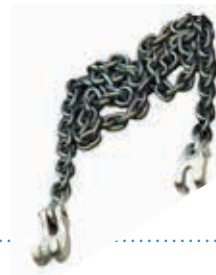

Art. 1502M	1500 mm, 2 ganci manine/claws
Art. 2002M	2000 mm, 2 ganci manine/claws
Art. 2502M	2500 mm, 2 ganci manine/claws
Art. 3002M	3000 mm, 2 ganci manine/claws

## Prodotti correlati | Related products



Art. 129M | Rullo rinvio catena con gancio manina  
Pulley with 1 double hook



Art. 129S | Rullo rinvio catena con gancio semplice  
Pulley with 1 simple hook

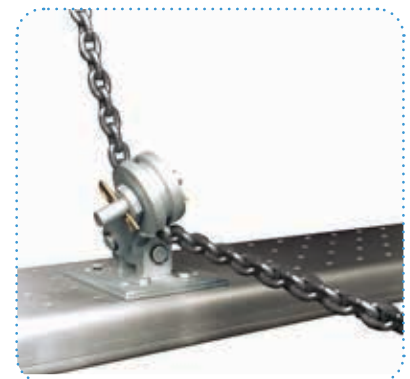

Art. 132 | Rullo rinvio per catena  
Pull down wheel



# fast dent repair

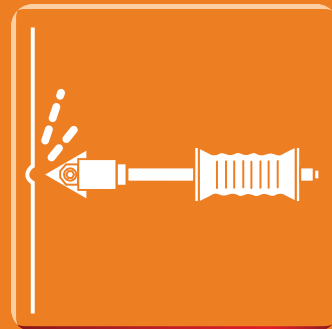

Moderni e veloci sistemi di riparazione richiedono l'utilizzo di attrezzature e manufatti progettati e costruiti appositamente per risolvere in poco tempo ma con estrema precisione alcune funzioni fondamentali.

In questa linea è possibile trovare utensili e martelli, integrati da accessori definiti "consumabili", come rondelle, fili ondulati, piastrine a saldare sia per carrozzerie in acciaio che in alluminio, ma anche pratici kit per riparazione ultraveloci ed economiche con l'utilizzo di apposite colle.

---

Modern and fast repair systems require the use of equipment and products designed and manufactured specifically to solve basic functions quickly and precisely.

In this line you can find tools and hammers, complemented by accessories called "consumables" such as washers, corrugated wires, plates to be welded both for steel and aluminium bodywork, but also practical kits for ultra-fast and low-cost repairs with the use of special glues.



## MORSETTO RAPIDO IN ALLUMINIO | ALUMINIUM FAST CLAMP Art. 156A



**Art. 156A**  
Morsetto di tiro in alluminio per lamierini a saldare, completo di n. 3 lamierini in ferro. Pratico, leggero, offre una elevata sicurezza e forza di tiro. Utilizzabile per riparazioni di lamierati in acciaio e/o alluminio, grazie ai lamierini specifici.

Pull clamp made of aluminium, complete with 3 weld on steel plates. Very light and handy, yet strong and performing.  
It can be used for larger dent repair on steel as well aluminium panels, thanks to the dedicated weld on plates.



Caratteristiche tecniche Technical specifications		156A
Materiale Material		Alluminio Aluminium
Larghezza presa di tiro Pulling width	mm	45
Forza di tiro Pulling strenght	ton	3*
Peso Weight	kg	0,3

\*N.B: i piastrini si rompono a 1,2 ton / weld on plates come off at 1,2 ton pull

### Consumabili | Consumables



80 X 25 mm

Art. 157 | 5 x  
Piastrine acciaio  
Weld on plates steel



80 X 40 mm

Art. 158 | 5 x  
Piastrine acciaio  
Weld on plates steel



80 X 75 mm

Art. 159 | 5 x  
Piastrine acciaio  
Weld on plates steel



80 X 25 mm

Art. 157A | 5 x  
Piastrine alluminio  
Weld on plates aluminium



80 X 40 mm

Art. 158A | 5 x  
Piastrine alluminio  
Weld on plates aluminium



80 X 75 mm

Art. 159A | 5 x  
Piastrine alluminio  
Weld on plates aluminium

### Prodotti correlati | Related products



Art. 171A | Martello completo di morsetto/testina in alluminio e n. 3 lamierini in ferro  
Slide hammer with aluminium pulling head with 3 weld on plates



## ARTIGLIO Art. 170



### Art. 170

Artiglio è un utensile per la riparazione veloce ed economica di piccole ammaccature su lamierati. Artiglio è dotato di 9 ganci di tiro con foro asolato, che perciò si adattano perfettamente ad ogni deformazione del lamierato.

The pull claw ARTIGLIO is a tool for quickly and inexpensively repairing small dents on metal surfaces. The pull claw Artiglio features 9 pull hooks with slotted hole and this enables each claw to adapt perfectly to any dents in metal surfaces

Caratteristiche tecniche Technical specifications		170
Materiale Material		acciaio steel
Larghezza presa di tiro Pulling width	mm	140
Numero ganci Pool Hooks		9
Peso Weight	Kg	1,2

## Consumabili | Consumables



Art. 07501000 10 pz/pcs  
Art. 07501100 50 pz/pcs  
Confezione rondelle asolate ramate diritte  
Pack oval washer plated straight

## Prodotti correlati | Related products



Art. 171 | Martello di tiro  
Slide hammer



Art. 900 | Cinghie di tiro.  
Una confezione n° 3 cinghie.  
Pull straps.  
A pack of 3 straps





## MARTELLINO DI TIRO LEGGERO | SLIDE HAMMER Art. 171



### Art. 171

Martello di tiro per Artiglio è un utensile per la riparazione veloce ed economica di piccole ammaccature su lamierati. Il tiro, applicato mediante il martello all'Artiglio, agisce in modo progressivo rispetto all'entità del danno. Dotato di peso battente di 2 Kg.

Slide hammer for pull claw is a tool for quickly and inexpensively repairing small dents on metal surfaces. After the crimped wire or bits have been spot-welded to the damaged surface, use the slide hammer to pull out the dent gradually. Equipped with sliding weight 2 Kg.



Caratteristiche tecniche Technical specifications		171
Materiale Material		acciaio steel
Peso battente Sliding weight	Kg	2
Peso Weight	Kg	3,9

### Consumabili | Consumables



Art. 172 30 pz/pcs  
 Art. 173 50 pz/pcs  
 Art. 174 100 pz/pcs  
 Confezione fili ondulati per saldatura  
 Wiggly wires packages

### Accessori | Accessories



Art. 06500500 Gancio piastra M.16  
 M.16 hook plate



Art. 06530100 Testina tiro M16 a 6 ganci  
 6 hooks pull claw M16 thread

### Prodotti correlati | Related products



Art. CS050000 Sostegno magnetico per filo ondulato  
 Magnetic holder for wiggly wires



Art. D1800100 Elettrodo a punta per filo ondulato  
 Fine tip electrode to wiggly wire



## MARTELLO LEGGERO | LIGHT HAMMER Art. 171A



Art. 171A - Peso battente 2 kg.  
Martello di tiro completo di testina profilata in alluminio e di n. 3 lamierini in ferro per la riparazione veloce ed economica di ammaccature di piccole e medie dimensioni.  
Questa soluzione consente la riparazione anche in posizioni di lamierato in cui non possono essere applicati i tradizionali morsetti a ganasce. Utilizzabile anche su lamierati in alluminio grazie agli appositi piastrini fornibili a parte.

Art. 171A - Sliding weight 2 kg.  
Slide hammer complete with profiled aluminium fixture and 3 weld on plates for fast and effective repair of small and medium dents. This practical solution allows repairing also in positions where traditional clamps with jaws cannot be applied. Suitable for repair on aluminium panels thanks to the dedicated aluminium weld on plates, available separately.



Caratteristiche tecniche Technical specifications		171A
Materiale Material		Alluminio Aluminium
Larghezza presa di tiro Pulling width	mm	45
Forza di tiro Pulling strenght	ton	3*
Peso Weight	Kg	3,7

\* N.B: i piastrini si rompono a 1,2 ton / weld on plates come off at 1,2 ton pull

### Consumabili | Consumables

					
Art. 157   5x Piastrine acciaio Weld on plate steel	Art. 158   5x Piastrine acciaio Weld on plate steel	Art. 159   5x Piastrine acciaio Weld on plate steel	Art. 157A   5x Piastrine alluminio Weld on plate aluminium	Art. 158A   5x Piastrine alluminio Weld on plate aluminium	Art. 159A   5x Piastrine alluminio Weld on plate aluminium

### Prodotti correlati | Related products



Art. 156A | Morsetto di tiro in alluminio per lamierini a saldare, completo di n. 3 lamierini in ferro.  
Pull clamp made of aluminium, complete with 3 weld on steel plates.

## MARTELLINO CON PIASTRA | HAMMER WITH PLATE Art. 171D

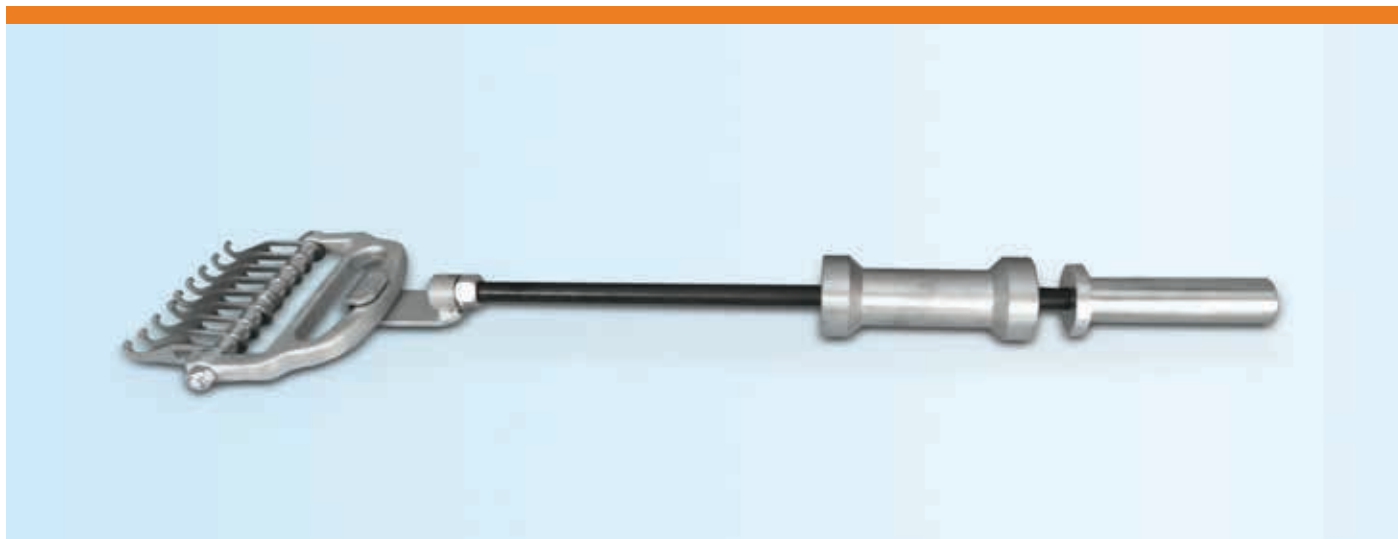

### Art. 171D

Martello di tiro con piastra per la riparazione veloce ed economica di piccole ammaccature su lamierati. Dotato di peso battente di 2 Kg. Il gancio "piastra" permette di bloccare perfettamente l'articolo 170 durante la fase di lavorazione.

Slide hammer with plate for quick and economical repair of small dents on metal surfaces.

With a sliding weight of 2 Kg, the "plate" fixture makes it possible to hold article 170 perfectly in place when working.

Caratteristiche tecniche Technical specifications		171D
Materiale Material		acciaio steel
Peso battente Sliding weight	Kg	2
Peso Weight	Kg	3,9

### Consumabili | Consumables



Art. 172 30 pz/pcs  
Art. 173 50 pz/pcs  
Art. 174 100 pz/pcs  
Confezione fili ondolati per saldatura  
Wiggly wires packages

### Accessori | Accessories

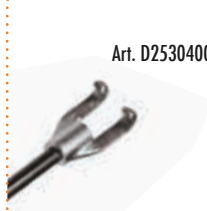

Art. D2530400 | Gancio doppio M.16  
M.16 double fixture



Art. 06530100 | Testina tiro M16  
a 6 ganci  
6 hooks pull claw  
M16 thread

### Prodotti correlati | Related products



Art. CS050000 | Sostegno magnetico per filo ondolato  
Magnetic holder for wiggly wires



Art. D1800100 | Elettrodo a punta per filo ondolato  
Fine tip electrode to wiggly wire







## MARTELLINO DI TIRO MANUALE | MANUAL SLIDE HAMMER Art. 171P - Art. 171Q - Art. 171R



Art. 171P | Martello in ferro M14 con impugnatura  
M14 slide hammer with rubber handle

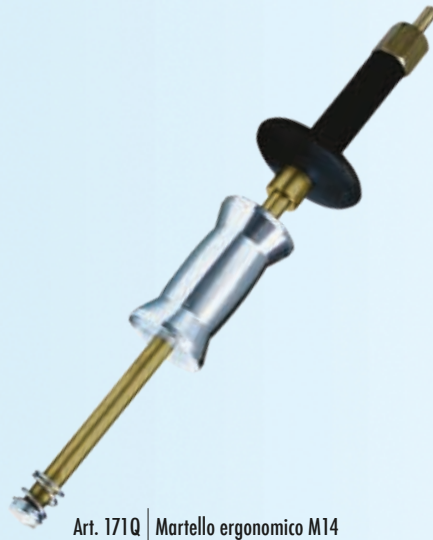

Art. 171Q | Martello ergonomico M14 con impugnatura per spotter  
M14 brass slide hammer with handle for spotter

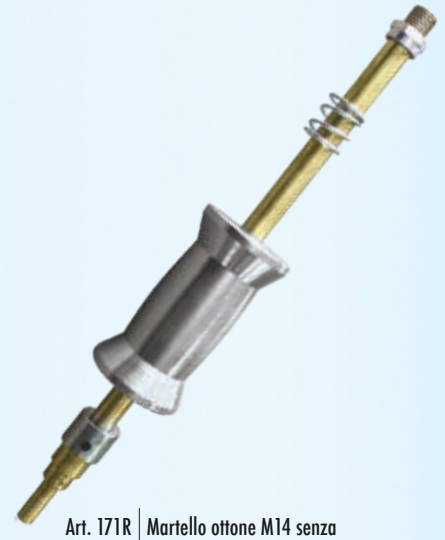

Art. 171R | Martello ottone M14 senza impugnatura per spotter  
M14 brass slide hammer without handle for spotter

### ACCESSORI DISPONIBILI PER MARTELLI 171P - Art. 171Q - Art. 171R | ACCESSORIES AVAILABLE FOR HAMMERS 171P - Art. 171Q - Art. 171R



Art. 06503000 | Testina tiro M14 a 6 ganci  
6 hooks pull claw M14 thread



Art. 06533800 | Adattatore M14 per prigionieri filettati M6  
M14 adapter for AL stud bolts M6



Art. 06531300 | Testina di tiro M14 per tassello per colla  
M14 adapter for glue pads



Art. CS039000 | 1 x Supporto rondelle 3 punte M.14  
M.14 electrode for 3-angled washers

### Consumabili | Consumables



Art. 07500400 | 100 pz/pcs M4X15  
Confezione prigioniero filettato in AL.Mg3  
Pack stud bolts in AL.Mg3



Art. 07500300 | 100 pz/pcs  
Confezione prigioniero filettato M 4 x 15 AlSi  
Pack stud bolts in AlSi M 4 x 15



Art. 07500050 | 10 pz/pcs M6  
Art. 07500100 | 10 pz/pcs M4  
Art. 07500150 | 10 pz/pcs M5  
Confezione golfare con filetto per saldatura in alluminio e tasselli colla filettati  
Pack threaded pull eye, for aluminium and glue pads with threaded pin.



Art. CS002000 | 20 pz/pcs  
Art. CS003000 | 50 pz/pcs  
Art. CS004000 | 100 pz/pcs  
Art. CS005000 | 1000 pz/pcs  
Confezione rondelle ramate a tre punte  
Pack 3-angled copper plated washers



## MARTELLINO DI TIRO MANUALE | MANUAL SLIDE HAMMER Art. 171P - Art. 171Q - Art. 171R

### Applicazioni | Use mode



### Prodotti correlati | Related products



Art. 177A | Mini martello con elettrodo a punta fine per scatolati  
Mini slide hammer with fine tip electrode for spotter



Art. 172 | 30 pz/pcs  
Art. 173 | 50 pz/pcs  
Art. 174 | 100 pz/pcs  
Confezione fili ondulati per saldatura  
Wiggly wires packages





## POWER LIFT Art. 175



### Art. 175

Power Lift è un utensile per la riparazione veloce ed economica di piccole ammaccature su lamierati. Power Lift è dotato di 3 ganci di tiro con foro asolato, che perciò si adattano perfettamente ad ogni deformazione del lamierato.

Il tiro, applicato mediante la lunga leva al filo ondulato, puntato sulla lamiera danneggiata, agisce in modo progressivo rispetto all'entità del danno.

The pull lever Power Lift is a tool for quickly and unexpensively repairing small dents on metal surfaces. The pull claw of Power Lift features 3 pull hooks with slotted hole and this enables each claw to adapt perfectly to any dents in metal surfaces.

After the crimped wire has been spot-welded to the damaged surface, use the built-in lever to pull out the dent gradually. Thanks to the slotted holes the hooks position themselves automatically pulling the deepest dent out first.



## Accessori | Accessories



Art. 0652000 | Supporto angolare  
Angle plate



Art. 0652010 | Artiglio di tiro a 5 ganci  
Pull claw with 5 hooks



Art. 0652020 | Artiglio di tiro a 7 ganci  
Pull claw with 7 hooks



## POWER LIFT Art. 175 - Art. 175M - Art. 175V

### Applicazioni | Use mode



Caratteristiche tecniche Technical specifications		175
Materiale Material		acciaio steel
Peso Weight	Kg	2,3

Power Lift trova impiego ottimale nell'applicazione della nuova tecnologia di riparazione mediante tasselli incollati per le piccole ammaccature senza danno di vernice.

Power Lift is a perfect tool to be used in combination with the new techniques to paintless repair requiring soft but continuous pulling on the glued pads.

### Prodotti correlati | Related products



Art. 175M - Power Lift,  
versione magnetica, magnetic version



Art. 175V - Power Lift,  
versione per tasselli per colla, version for glue pulling

### Consumabili | Consumables



Art. 172 30 pz/pcs  
Art. 173 50 pz/pcs  
Art. 174 100 pz/pcs  
Confezione fili ondulati per saldatura  
Wiggly wires packages

### Accessori | Accessories



Art. 06531100 1 pz/pcs  
Testina completa per tiro ventose per 175V  
Complete pull claw thread for 175V



## FALCON Art. 179

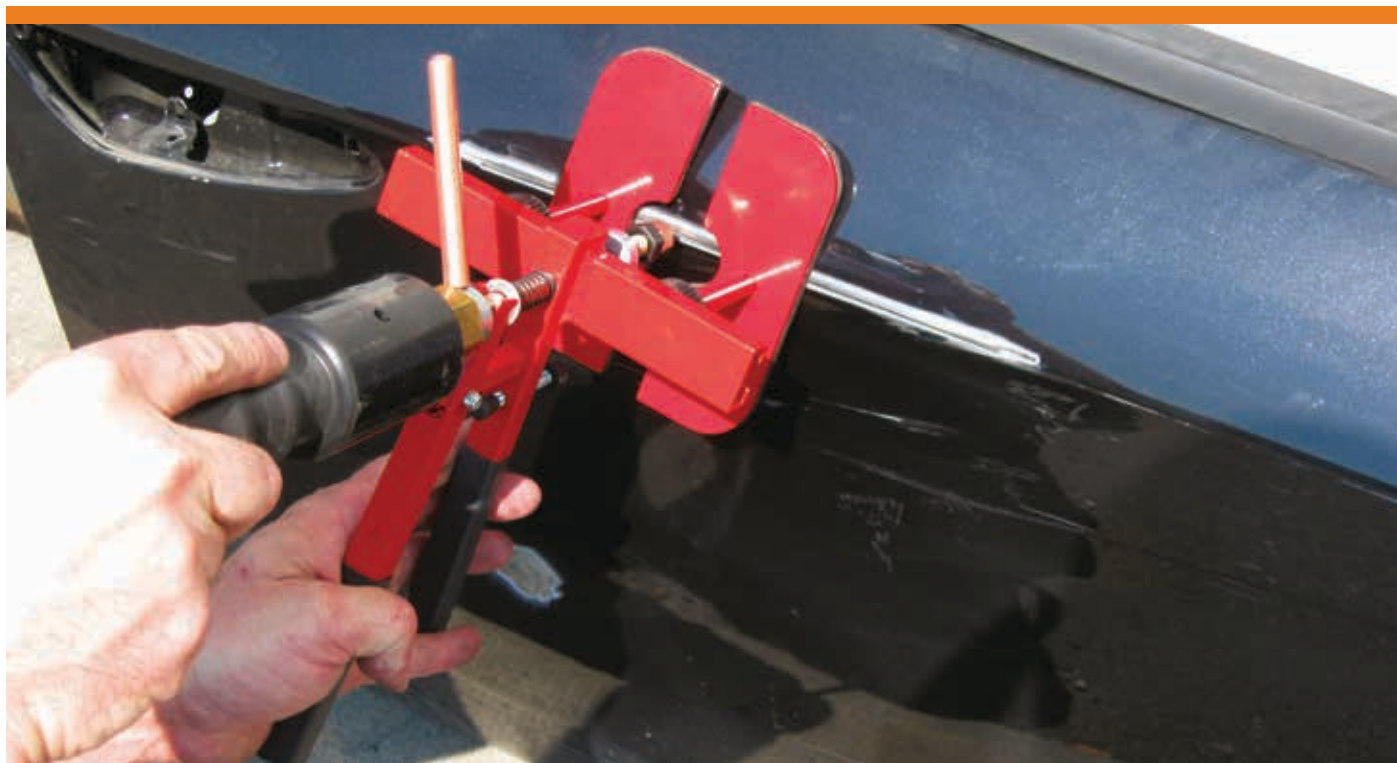

### Art. 179

Applicando il FALCON alla pistola dello spotter, è possibile sollevare facilmente e con precisione piccole e medie ammaccature sui lamierati, sia montati sulle vetture che smontati. L'elettrodo viene inserito direttamente nella apposita sede della pistola di puntatura, che viene operata con una mano, mentre il Falcon viene tenuto in posizione con l'altra mano.

Falcon è estremamente leggero e maneggevole; regolando la distanza fra i supporti può essere utilizzato per ammaccature di varie dimensioni.

Applying FALCON on the spotter gun allows easy, highly precise lifting of small and medium-sized dents on metal panels, either still fitted on vehicles or removed. The electrode is directly inserted in a socket provided in the spotter gun, which you can operate with one hand while holding Falcon in position with your other hand. Falcon is extremely lightweight and easy to handle; the distance between the supports can be adjusted according to the size of the dent.

## Accessori | Accessories



Art. 07505160 | kit piedi snodati 2 pz  
2 supports with mobile rests





## FALCON HAND PULLER Art. 179V



### Applicazioni | Use mode



Per riparazioni su lamierati in alluminio / For dent repair on aluminium panels

FALCON HAND PULLER è una versatile attrezzatura manuale per l'eliminazione delle ammaccature o "bolli" adatto a diverse tecniche di riparazione:

- tasselli incollati alla lamiera ove la vernice non sia stata danneggiata; uno speciale adattatore per i tasselli è fornito con HAND PULLER.
- tiro mediante rivetti o prigionieri filettati (lamierati di alluminio) applicati con spotter, nel caso ammaccature più pesanti; un apposito gancio è fornito in dotazione.

Dotato di piedi snodati per massima adattabilità a tutte le posizioni.

FALCON HAND PULLER is a versatile equipment for manual dent pulling by applying different repair techniques:

- plastic pads are glued to the metal sheet, in case of paintless repair: a special plastic pads adapter for glue pulling is provided with Hand Puller.
- spotting on of rivets or stud bolts (for example on sheets of aluminum), if dents are heavier; a pull hook is provided for the threaded eyebolts or bits.

Equipped with mobile supports for maximum flexibility in use.

### Dotazioni standard | Standard equipment



Art. 179V | Pistola manuale in alluminio con piedi snodati  
Hand puller in aluminum with mobile feet

1 adattatore per tasselli per colla  
1 adapter for glue pads

1 gancio di tiro per golfari e bits  
1 pull hooks for threaded rings and bits



## CARICATORE RONDELLE ASOLATE DIRITTE | CHARGER FOR OVAL STRAIGHT WASHERS Art. 520



### Art. 520

Accessorio per Spotter. Il caricatore può contenere fino a 40 rondelle\* asolate diritte. La praticità del sistema consente di ridurre i tempi di applicazione anche del 70% ed una maggiore precisione. Costruito interamente in alluminio, leggero, maneggevole, particolarmente robusto, non necessita di manutenzione. Può essere applicato a tutti gli spotter in commercio.

\* Rondelle non comprese nella confezione standard.

Charger for Oval Washers. The may contain up to 40 oval washers\*.

The system is so practical that allows to reduce times of application until the 70% and a further precision. Completely manufactured in aluminium, light and easy to use, particularly strong it doesn't need any maintenance. It could be applied to all the spotters present on the market.

\* Washers not included in the standard package.



## Accessori | Accessories



Art. 523 | Supporto da tavolo  
Table stand



Art. 524 | Caricatore per pulire rondelle  
Charger for cleaning washer



## CARICATORE RONDELLE ASOLATE DIRITTE | CHARGER FOR OVAL STRAIGHT WASHERS ART. 520

### Applicazioni | Use mode



### Prodotti correlati | Related products

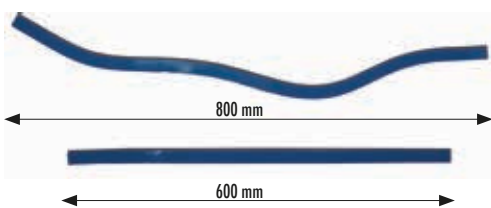

Art. 570 | Striscia magnetica flessibile  
Magnetic flexible strip



Art. 07501000 - 10 pz.  
Art. 07501100 - 50 pz.  
Confezione rondelle asolate ramate diritte  
Pack oval washer plated straight



Art. 06500300 | Asta in acciaio L.200 mm.  
Steel rod L. 200 mm

Art. 06500400 | Asta in acciaio L.380 mm.  
Steel rod L. 380 mm





## CARICATORE PER PULIRE RONDELLE | CHARGER FOR CLEANING WASHER Art. 524



### Art. 524

Caricatore per la pulizia delle rondelle asolate; costruito in alluminio leggero e di facile utilizzo, può contenere fino a 40 rondelle. Dopo aver riempito il caricatore con le rondelle, utilizzando un piccolo smeriglio a nastro, è possibile pulirle con facilità e rapidità. Completata la pulizia le rondelle sono pronte per un nuovo utilizzo.

Charger for cleaning oval washers; made in light aluminium and easy to use, it can take up to 40 washers. After filling the charger with washers, they can be cleaned easily and quickly using a small belt sander. Once cleaned, the washers are ready to be used again.

## Prodotti correlati | Related products



Art. 520 | Caricatore per rondelle asolate  
Charger oval washers



Art. 07501000 - 10 pz | Confezione rondelle asolate ramate diritte  
Art. 07501100 - 50 pz | Pack oval washer plated straight





## SPEEDY P Art. 560 - 560/S (mod. 60 Hz) - 563



### Art. 560 - 560/S (mod. 60 Hz)

Speedy P è un kit di pronto intervento per la riparazione veloce ma sicura di tutte le parti in plastica montate sui veicoli di ogni tipo.

Il funzionamento, semplice ed intuitivo, si basa sull'utilizzo di "graffette" in acciaio inox, di varie forme e diametri, che vengono immerse a caldo nelle parti da riparare unendole in modo definitivo (cucitura meccanica con fusione a caldo).

Il kit è composto da un dispositivo per il riscaldamento e controllo della temperatura (3 livelli di temperatura), dalla pistola ergonomica e da una serie di "graffette".

Speedy P is an emergency kit for the quick and safe repair of all plastic automotive parts.

Its simple, user-friendly operation is based on the use of stainless steel "staples", of various shapes and diameters, which are immersed while hot into the parts to be repaired, bonding them definitively (hot-melt mechanical seam).

The kit is made up of a heating and temperature check device (3 temperature levels), an ergonomic gun and a series of staples.

### Art. 563

Speedy P Economy, versione senza graffette

Economy version without staples

## Dotazioni standard | Standard equipment

Il contenuto del kit comprende:

- valigetta in plastica
- dispositivo elettrico riscaldante
- pistola saldatrice ergonomica per inserimento graffette
- cassettona con 250 graffette standard (50 per tipo, 5 tipi diversi) \*

The kit contains:

- plastic case
- electrical heating device
- ergonomic sealing gun for inserting the staples
- box with 250 standard staples (50 per type, 5 different types) \*

Art. CS076000 Cassettona con 250 graffette standard\*  
Box with 250 standard staples \*







## SPEEDY P Art. 560

### Applicazioni | Use mode



L'utilizzo della pistola saldatrice e delle "graffette" in dotazione, consentono la riparazione di ogni tipo di componente in plastica dell'automobile:

- paraurti
- mascherine
- carenature
- spoiler
- cruscotti
- fari

Using the sealing gun and the staples provided enables any type of plastic car part to be repaired:

- bumpers
- grilles
- fairings
- spoilers
- dashboards
- headlights

### Consumabili | Consumables

Art. 0750900\* Graffette "ondulata" Ø 06  
"Wavy" staples Ø 06



Art. 07509100\* Graffette "ondulata" Ø 08  
"Wavy" staples Ø 08



Art. 07509200 Graffette "lunga" Ø 08  
"Long" staples Ø 08



Art. 07509300\* Graffette "angolare" Ø 08  
"Corner" staples Ø 08



Art. 07509400\* Graffette "ondulata alta" Ø 06  
"High wavy" staples Ø 06



Art. 07509500\* Graffette "ondulata alta" Ø 08  
"High wavy" staples Ø 08



Art. 07509600 Graffette "angolo interno 90°" Ø 08  
"Internal corner 90°" staples Ø 08



Art. 07509700 Graffette "angolo esterno 90°" Ø 08  
"External corner 90°" staples Ø 08



Art. 07509800 Graffette "composte" Ø 08  
"Composed" staples Ø 08



Confezione 100 graffette  
Pack of 100 staples





## KIT COLLA | GLUE KIT Art. 580 - Art. 585 - Art. 587 (senza pistola - without gun)



**Art. 580**  
Questo sistema di riparazione rapida utilizza tasselli di diversa grandezza e forma, che opportunamente incollati sul lamierato, permettono di eliminare ammaccature di varie dimensioni, senza sverniciare la zona di lavoro. Il principio è lo stesso dello spotter: invece di saldare un elettrodo, si incollano uno o più tasselli, in base all'ampiezza della superficie da riparare, si raddrizza utilizzando l'attrezzo adeguato, e si elimina la colla residua mediante il solvente.  
Il Kit Colla Stanzani è stato appositamente studiato per essere integrato nella completa gamma di accessori Spot Power System, destinato alla riparazione di lamierati mediante l'uso di spotter. Infatti, oltre al martello battente compreso nel kit, si possono utilizzare anche gli articoli art. 175V, 179V e 750, a seconda dell'estensione del danno da riparare.  
Il Kit Colla Stanzani è ottimo nella raddrizzatura delle ammaccature da grandine, nonché dei lamierati in alluminio, ove questa lavorazione non invasiva è sufficiente per riottenere la superficie originale, grazie alle caratteristiche meccaniche di questo metallo.

This rapid repair system uses pads of different size and shape, which properly glued onto the panel sheet, allow to remove painless dents of various sizes. The principle is the same as the spotter yet, instead of welding an electrode, one or more pads, according to the extent of damaged area, are glued on the panel sheet. Using the pulling accessory suitable to the damage extension, the dent is pulled out. At the end the residual glue is eliminated with solvent.  
The Glue Kit Stanzani is designed to be integrated into the full range of accessories Spot Power System, for panel repair through the use of spotter. Indeed, in addition to the slide hammer included in the kit, you can also use the item 175V, 179V and 750, depending on the required repair technique.  
The Glue Kit Stanzani is excellent for fast hail damage repair and for dent repair on aluminum sheets, where this non invasive technique is perfectly suitable to regain the original flat surface, thanks to the mechanical characteristics of this metal.

### Dotazioni standard | Standard equipment

Art. 580	Kit colla con pistola / Glue kit with gun
Art. 00171P00	Martello ferro M.14 c/impugnatura / M14 slide hammer with rubber handle
Art. 06531300	Testina alu M.14 per tiro ventose / M14 adapter for glue pads
Art. 06533800	Testina m.14 per filetti m6 / M14 adapter for m6 threaded pin
Art. 07500050	10 x golfare m.6 / 10 x threaded pull eye m6
Art. 07508000	5 x ventosa tonda ø20 mm. / 5 x glue pads ø20 mm
Art. 07508100	5 x ventosa ovale / 5x oval glue pads
Art. 07508200	5 x ventosa ø30 mm./ 5 x glue pads ø30 mm
Art. 07508300	5 x ventosa c/taglio ø40 mm. / 5 glue pads with reliefs ø40 mm
Art. D6300900	Bulino per colla / Glue burin
Art. 07506100	Conf. 10 pz colla nera / 10 pcs black glue sticks
Art. 07506200	Conf. 10 pz colla opalina / 10 pcs opaline glue sticks
Art. C7501800	Pistola professionale per colla / 1 pc professional glue gun
Art. 585	Kit colla senza pistola / Glue kit without glue gun





## KIT COLLA | GLUE KIT Art. 580 - Art. 585 - Art. 587

### Applicazioni | Use mode



Art. 179V



Art. 750



Art. 175V

### Consumabili | Consumables

Art. 07500050	10 x golfare m.6 / 10 x threaded pull eye m6
Art. 07508000	5 x ventosa tonda ø20 mm. / 5 x glue pads ø20 mm
Art. 07508100	5 x ventosa ovale / 5x oval glue pads
Art. 07508200	5 x ventosa ø30 mm./ 5 x glue pads ø30 mm
Art. 07508300	5 x ventosa c/taglio ø40 mm. / 5 glue pads with reliefs ø40 mm
Art. 07506150	Conf. 500 pz colla nera / 500 pcs black glue sticks for warm climate
Art. 07506250	Conf. 500 pz colla opalino / 500 pcs opaline glue sticks for cold climate

Art. 587 | Kit consumabili colla / Kit with glue pads and glue sticks

Contiene / Contains:

Art. 07508050	5 x ventosa tonda Ø20 alta trazione / 5 x glue pads Ø 20 mm high traction
Art. 07508150	5 x ventosa ovale alta trazione / 5 x oval glue pads high traction
Art. 07508250	5 x ventosa tonda Ø30 alta trazione / 5 x glue pads Ø 30 mm high traction
Art. 07508350	5 x ventosa tonda Ø40 alta trazione / 5 x glue pads Ø 40 mm high traction
Art. 07508000	5 x ventosa tonda Ø 20 mm. / 5 x glue pads Ø 20 mm
Art. 07508100	5 x ventosa ovale / 5 x oval glue pads
Art. 07508200	5 x ventosa Ø 30 mm./ 5 x glue pads Ø 30 mm
Art. 07508300	5 x ventosa c/taglio Ø 40 mm. / 5 glue pads with reliefs Ø 40 mm
Art. 07506100	10 pz colla nera / 10 pcs black glue sticks
Art. 07506200	10 pz colla opalino / 10 pcs opaline glue sticks



### Prodotti correlati | Related products



Art. 179V

Pistola manuale in alluminio con piedi snodati  
Hand puller in aluminum with mobile feet

1 adattatore per ventose  
1 adapter for glue pads

1 gancio di tiro per golfari e bits  
1 pull hooks for threaded rings and bits



Art. 175V

Power Lift,  
Versione per tasselli per colla  
Version for glue pulling





## KIT COLLA PROFESSIONALE | PROFESSIONAL GLUE KIT Art. 586



**Art. 586**  
 Kit professionale per la riparazione rapida dei lamierati senza intervenire con attività di sverniciatura. Un sistema moderno di grande valore aggiunto per le caratteristiche tecniche e qualitative dei numerosi accessori di cui si compone. Si utilizza con lo stesso principio dello spotter: invece di saldare un elettrodo, si incollano uno o più tasselli, in base all'ampiezza della superficie da riparare e si raddrizza la parte del lamierato interessata utilizzando l'attrezzo adeguato procedendo ad eliminare la colla residua mediante l'apposito solvente. La valigetta, pratica e robusta, contiene tutti gli accessori ed i consumabili.

Professional kit for rapid sheet metal repairs without paint removal. A modern, high added value system due to the technical characteristics and quality of the numerous accessories. It is used with the same principle as the spotter: instead of welding an electrode, one or more pieces are glued, based on the size of the surface being repaired, and the sheet metal part is straightened using the tool, then the residual glue is removed using solvent. The practical, robust case contains all the accessories and consumables.

### Dotazioni standard | Standard equipment

Art. C2300300	Valigetta nera /Black briefcase	Art. 07508350	5 x ventosa alta trazione ø40 mm / 5 x high traction glue pads ø40 mm
Art. 179V	Pistola manuale in alluminio con piedi snodati / Hand puller in aluminium with mobile feets	Art. 07508400	25 x ventose sferiche assortite / 25 x assorted spherical glue pads
Art. 740	Mini traversa con piedi fissi, tirante a 4 ganci (L= 400 mm)	Art. 07508450	Conf. 25 ventose varie forme (5 pz x 5) / Kit 25 glue pads different shapes (5 pcs x 5)
	Mini Dent Lifter with supports, puller and 4 hooks (L= 400 mm)	Art. 07508970	5 x confezione multipads assortiti / 5 x assorted multipads
Art. 218	Martello in alluminio penna tonda / Aluminium round pen hammer	Art. D6300900	Bulino per colla / Glue burin
Art. 171P	Martello in ferro M 14 con impugnatura / M14 slide hammer with rubber handle	Art. 07506100	Conf. 10 pz colla nera / 10 pcs black glue sticks
Art. 06531300	Testina in alluminio M14 per tiro ventose / M14 aluminium adapter for glue pads	Art. 07506200	Conf. 10 pz colla opalino / 10 pcs opaline glue sticks
Art. 06533800	Testina m.14 per filetti m6 / M14 adapter for m6 threaded pin	Art. C7501800	Pistola professionale per colla / 1 pc professional glue gun
Art. 07500050	10 x golfare m.6 / 10 x threaded pull eye m6		
Art. 07508000	5 x ventosa tonda ø20 mm. / 5 x glue pads ø20 mm		
Art. 07508100	5 x ventosa ovale / 5x oval glue pads		
Art. 07508200	5 x ventosa ø30 mm. / 5 x glue pads ø30 mm		
Art. 07508300	5 x ventosa c/taglio ø40 mm. / 5 glue pads with reliefs ø40 mm		
Art. 07508050	5 x ventosa alta trazione ø20 mm / 5 x high traction glue pads ø20 mm		
Art. 07508150	5 x ventosa alta trazione ovale / 5 x high traction oval glue pads		
Art. 07508250	5 x ventosa alta trazione ø30 mm / 5 x high traction glue pads ø30 mm		



## Consumabili per Art. 580, 585 e 586 | Consumables for Art. Art. 580, 585 and 586

Art. 07506100  
Conf. 10 pz colla nera  
10 pcs black glue sticks



Art. 07506150  
Conf. 500 pz colla nera  
500 pcs black glue sticks

Art. 07506200  
Conf. 10 pz colla opalino  
10 pcs opaline glue sticks



Art. 07506250  
Conf. 500 pz colla opalino  
500 pcs opaline glue sticks

Art. 07500050  
Conf. 10 pz golfare M6  
10 pcs threaded pull eye M6



Art. 07508000  
Conf. 5 pz ventosa tonda Ø20  
5 pcs glue pads Ø20



Art. 07508100  
Conf. 5 pz ventosa ovale  
5 pcs oval glue pads



Art. 07508200  
Conf. 5 pz ventosa tonda Ø30  
5 pcs pz glue pads Ø30



Art. 07508300  
Conf. 5 pz ventosa tonda Ø40  
5 pcs glue pads Ø40



Art. 07508050  
Conf. 5 pz ventosa tonda Ø20 - alta trazione  
5 pcs glue pads Ø20 - high traction



Art. 07508150  
Conf. 5 pz ventosa ovale - alta trazione  
5 pcs oval glue pads - high traction



Art. 07508250  
Conf. 5 pz ventosa tonda Ø30 - alta trazione  
5 pcs glue pads Ø30 - high traction



Art. 07508350  
Conf. 5 pz ventosa tonda Ø40 - alta trazione  
5 pcs glue pads Ø40 - high traction



Art. 07508400  
Conf. 25 pz ventosa sferica - assortito  
25 pcs spherical glue pads - assorted



Art. 07508450  
Conf. 25 ventose varie forme  
(5 pz x 5)  
Kit 25 glue pads different shapes  
(5 pcs x 5)



Art. 07508910  
Conf. 10 pz ventosa azzurra tonda Ø36  
10 pcs oval light blue glue pads Ø36



Art. 07508920  
Conf. 10 pz ventosa gialla tonda Ø40  
10 pcs round yellow glue pads Ø40



Art. 07508930  
Conf. 10 pz ventosa gialla ovale 33x47  
10 pcs oval yellow glue pads 33x47



Art. 07508940  
Conf. 10 pz ventosa viola tonda Ø40  
10 pcs round violet glue pads Ø40



Art. 07508950  
Conf. 10 pz ventosa viola ovale 33x47  
10 pcs oval violet glue pads 33x47



Art. 07508500  
Conf. 3 pz blu multipads 6x36x156 piana  
3 pcs blue multipads 6x36x156 flat

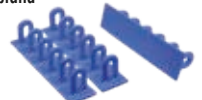

Art. 07508600  
Conf. 3 pz verde multipads 6x22x156 - sferica  
3 pcs green multip. 6x22x156 - spherical



Art. 07508700  
Conf. 3 pz grigio multipads 6x50x156 - piana  
3 pcs grey multipads 6x22x156 - flat



Art. 07508800  
Conf. 3 pz rosso multipads 6x22x156 - piana  
3 pcs red multipads 6x22x156 - flat



Art. 07508900  
Conf. 3 pz yellow multip. 6x22x156 - conica  
3 pcs yellow multipads 6x22x156 - cone-shaped



Art. 07508970  
Conf. 5 pz multipads - assortiti  
5 pcs multipads - assorted



### Nota tecnica

L'alta trazione di questa serie di ventose si deve alla particolare conformazione del fondo. Le scanalature consentono una migliore distribuzione e presa della colla

Technical note  
The high traction of this series of suction cups is due to the special shape of the bottom. The grooves spread the glue and provide a better gripping action.





## MINI TRAVERSA | MINI DENT LIFTER Art. 740



Art. 740  
Mini traversa con piedi fissi, Completa di traversa, piedi, tirante a 4 ganci (L= 400 mm)

Mini Dent Lifter with supports, puller and 4 hooks (L= 400 mm)

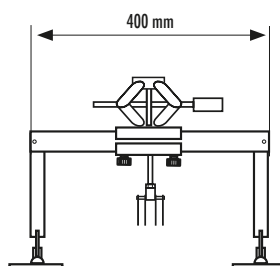

## Consumabili | Consumables



Art. 07501000 10 pz/pcs  
Art. 07501100 50 pz/pcs  
Confezione rondelle asolate  
ramate diritte  
Pack oval washer plated straight



Art. 07502000 10 pz/pcs  
Art. 07502100 50 pz/pcs  
Confezione rondelle asolate  
ramate piegate  
Pack oval washer plated twister





## TRAVERSA DI TIRO | PULL CROSSBAR Art. 750

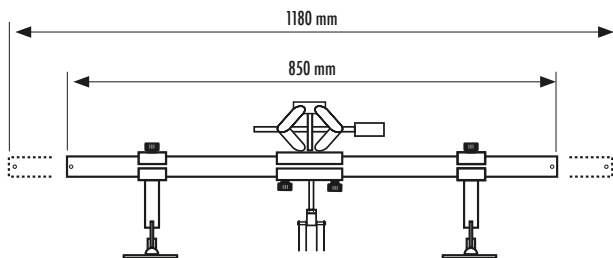

Caratteristiche tecniche Technical specifications		750
Materiale Material		Alluminio Aluminium
Lunghezza totale Total Length	mm	850
Peso Weight	Kg	5,4

### Art. 750

Traversa in alluminio completa di n. 2 artigli a 4 e 6 ganci e n. 2 ventose.

Dispositivo di tiro ad elevata precisione. Consente tiri di grande potenza con minimo sforzo applicato.

E' adatta per riparazioni anche su parti di veicolo molto rigide come scatolati e sottoporta. Leggerissima e versatile può essere impiegata con diverse tecniche di riparazione:

- per raddrizzare ammaccature su lamierati in acciaio mediante rondelle saldate
- per raddrizzare ammaccature su lamierati in alluminio mediante prigionieri saldati + relativi golfari filettati
- per raddrizzare ammaccature su lamierati in acciaio e alluminio mediante tasselli incollati

Pull crossbar in aluminium complete with handle, 2 claws with 4 and 6 hooks and 2 suction cups. Pulling device for high accuracy.

It allows great power working with minimum effort applied. It is suitable for repairs on hard vehicle parts such as skinned panels and under pillar. Lightweight and versatile can be used with different techniques of repairing:

- To straighten dents on steel sheets by means of welded bits
- To straighten dents on aluminum sheets by means of welded stud bolts + threaded eyebolts
- To straighten dents on sheets of steel and aluminum using glued pads

### Accessori | Accessories

#### Art. 710

Traversa di tiro extra lunga in alluminio (L= 1180 mm), SOLO TRAVERSA  
Extra long crossbar, in aluminium (L= 1180 mm), ONLY CROSSBAR





## X MONSTER Art. 775



### Applicazioni | Use mode



#### Art. 775

Questo piccolo e versatile braccio di tiro è il complemento ideale per la gamma Spot Power System, dedicata alla riparazione veloce delle ammaccature sui lamierati.

X Monster è particolarmente adatto per raddrizzare ammaccature consistenti, sia nella parte bassa dei veicoli che nelle posizioni meno accessibili dei veicoli.

È dotato di un braccio posizionabile perpendicolare al tiro azionato da un martinetto idraulico. Di peso ridotto, può essere agilmente spostato grazie alle 2 ruote presenti sotto il montante.

This small and versatile pull arm is the ideal complement for the range Spot Power System, dedicated to quick repair of dents on panel sheet.

X Monster is particularly suitable to straighten dents substantial, both in the lower part of vehicles in less accessible positions of the vehicles.

It is equipped with a positionable arm perpendicular to shoot driven by a hydraulic jack. Lightweight, can be easily moved around thanks to 2 wheels applied under the vertical post.



## X MONSTER Art. 775

### Applicazioni | Use mode



### Caratteristiche tecniche Technical specifications

		775
Materiale Material		acciaio steel
Peso Weight	Kg	32

### Dotazione standard | Standard Equipment

Squadra in acciaio, Steel arm  
 Martinetto idraulico, Hydraulic jack  
 Catena, Chain  
 Manina a 6 ganci, 6 hooks claw  
 1 perno x rondelle asolate, 1 bar to bits  
 Piastra braccio mobile in acciaio, Mobile arm steel plate

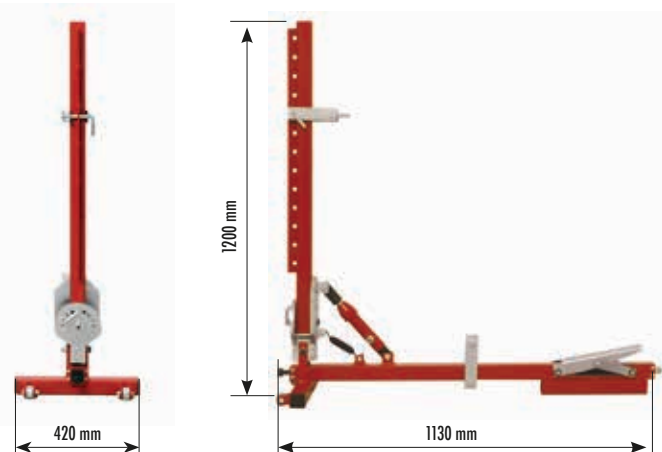

### Accessori | Accessories

Questi accessori non sono inclusi nella dotazione standard. Vanno ordinati separatamente / These accessories are not included in standard delivery and must be ordered separately



Art. 07700100 | Kit pompa 4 ton con tubo ad alta pressione  
 Nota: accessorio extra UE  
 Kit with hydraulic pump including high pressure hose 4 ton  
 Note: accessory extra UE

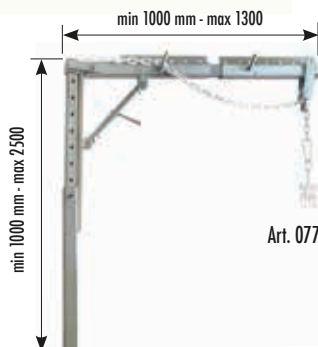

Art. 07700400 | Kit tiro verticale standard (fornito senza catena di tiro e manina)  
 Kit vertical pull (supplied without pull chain and hooks claw)



Art. 07700250 | Piastra sotto ruota  
 Plate under the wheel

Art. 07700300 | Kit contrasto tamponi  
 Pair of rubber pads



Art. 07700500 | Kit bracci supporto laterali con piattelli in gomma  
 Side supporting arms with pads





## MONSTER SYSTEM Art. 777



**Art. 777**  
Sistema di tiro completo ideale per la gamma Spot Power System, dedicata alla riparazione veloce delle ammaccature anche consistenti. Monster System è particolarmente adatto per raddrizzare ammaccature consistenti, specialmente nella parte alta dei veicoli, ove la traversa di tiro art. 750 potrebbe risultare insufficiente, oppure di scomoda applicazione. E' dotato di un martinetto idraulico, per ridurre al minimo lo sforzo dell'operatore. Di peso ridotto, può essere agilmente spostato grazie alle 2 ruote applicate sotto il montante.

This pull arm system is the ideal complement for the range Spot Power System, dedicated to quick repair of dents also consistent. Monster System is particularly suitable to straighten substantial dents, especially in the high part of vehicles, where the crossbar item 750 may be insufficient or its application complicated. It is equipped with a hydraulic jack in order to minimize the effort of the operator. Lightweight, can be easily moved around thanks to 2 wheels applied under the vertical post.



## MONSTER SYSTEM Art. 777

### Dotazioni standard | Standard equipment



Art. 775 X MONSTER  
Braccio di tiro  
Pull arm

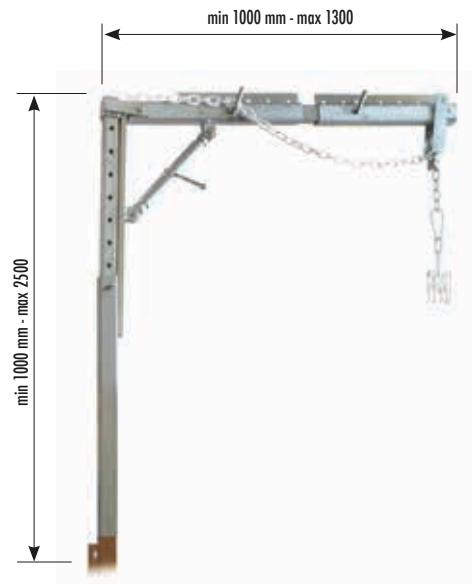

Art. 07700400 Kit tiro verticale standard  
(fornita senza catena di tiro e manina)  
Kit vertical pull  
(supplied without pull chain and  
hooks claw)



Art. 07700500 Kit bracci supporto laterali con piattelli in gomma  
Side supporting arms with pads



Art. 06500350 Asta in acciaio esagonale L.200  
Hexagonal steel rod L.200



Art. 06500450 Asta in acciaio esagonale L.300  
Hexagonal steel rod L.300



Art. 07700100 Kit pompa 4 ton con tubo ad alta pressione  
Nota: accessorio extra UE  
Kit with hydraulic pump including high  
pressure hose 4 ton  
Note: accessory extra UE



Art. 07700250 Piastra sottoruota  
Plate under the wheel



Art. 07700300 Kit contrasto tamponi  
Pair of rubber pads



# SPOT POWER 230 Art. 610SG



Art. 610SG - Spot Power 230 Evolution, A innesto automatico con comando remoto, monofase 230 Volt

Art. 610SG - Spot Power 230 Evolution, Digital Spotter automatic with remote control, single Phase 230 Volt.

## Caratteristiche tecniche | Technical specifications

Potenza nominale al 50%	Rated power at 50%	KVA	Sn 4
Corrente sec. di corto circuito	Sec. short circuit current	KA	3500
Corrente sec. max di saldatura	Sec. max welding current	KA	2800
Tensione secondaria	Secondary voltage	V	7,5
Alimentazione Mod. 230	Single-phase power voltage	V	230
Frequenza nominale	Nominal frequency	HZ	50/60
Fusibili ritardati	Delayed fuses	A	16
Livello temp. trasformatore	Temperature level of power transformer		F
Cl. isolamento trasformatore	Power transformer insulation class		F
Termostato di sicurezza su connettori	Safety thermostat on cable connectors	°C	70
Lunghezza cavo torcia	Length and cross section of torch cable	mm/mmq	2500/50
Lunghezza cavo massa	Length and cross section of earth lead	mm/mmq	2000/50
Dimensioni Spot Power 230 e 400	Spot Power 230 e 400 dimensions	mm	240x465x295
Peso	Weight	Kg	24

## Dotazioni | Equipment

- Torcia attacco universale
- Martello a battente con elettrodo puntatura e calde
- Telecomando con cavo
- 2 cavi
- 1 massa rapida
- Torch universal connector
- Gun with slide hammer with electrodes (1 spotting, 1 x shrinking)
- Remote control with cable
- 2 cables
- 1 quick earth electrode

## Dimensioni | Dimension

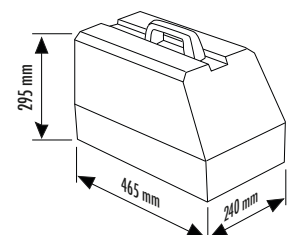





## SPOT POWER 400 Art. 630SG



Art. 630SG - Spot Power 400 Evolution,  
A innesto automatico con comando remoto, trifase 400 Volt

Item 630SG - Spot Power 400 Evolution,  
Digital Spotter automatic with remote control, 3-phase 400 Volt

### Caratteristiche tecniche | Technical specifications

Potenza nominale al 50%	Rated power at 50%	KVA	Sn 4
Corrente sec. di corto circuito	Sec. short circuit current	KA	3500
Corrente sec. max di saldatura	Sec. max welding current	KA	2800
Tensione secondaria	Secondary voltage	V	7,5
Alimentazione Mod. 400	Three-phase power voltage	V	400
Frequenza nominale	Nominal frequency	HZ	50/60
Fusibili ritardati	Delayed fuses	A	16
Livello temp. trasformatore	Temperature level of power transformer		F
Cl. isolamento trasformatore	Power transformer insulation class		F
Termostato di sicurezza su connettori	Safety thermostat on cable connectors	°C	70
Lunghezza cavo torcia	Length and cross section of torch cable	mm/mmq	2500/50
Lunghezza cavo massa	Length and cross section of earth lead	mm/mmq	2000/50
Dimensioni Spot Power 230 e 400	Spot Power 230 e 400 dimensions	mm	240x465x295
Peso	Weight	Kg	24

### Dotazioni | Equipment

- Torcia attacco universale
- Martello a battente con elettrodo puntatura e calde
- Telecomando con cavo
- 2 cavi
- 1 massa rapida
- Torch universal connector
- Gun with slide hammer with electrodes (1 spoting, 1 x shrinking)
- Remote control with cable
- 2 cables
- 1 quick earth electrode

### Dimensioni | Dimension

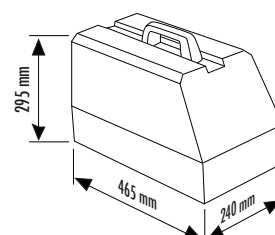



# ALU SPOT POWER Art. 640SG



### Art. 640SG

ALU Spot Power 230 Evolution, Spotter digitale per lamierati di alluminio dotato di grande potenza e regolazione di massima precisione:

- Innesto automatico
- Comando elettronico, con 4 menù di potenza reimpostati
- Display digitale

Consente un tiro molto potente, senza bruciare il lamierato. Completo di 2 cavi di messa a terra con relative masse, e di prigionieri speciali al silicio ed al magnesio adatti a qualsiasi lega di alluminio.

### Item 640SG

Digital spotter for work on aluminium panels, extremely powerful with precision regulation feature:

- Automatic connection
- Electronically controlled with 4 preset power menus
- Powerful dent pulling without burning the panel

Fitted with 2 earthing cables and respective connectors and special silicon and magnesium stud bolts suitable for all aluminium alloys.

## Caratteristiche tecniche | Technical specifications

Capacità	Capacity	mF	66
Tensione di alimentazione monofase	Single-phase power voltage	V	230
Frequenza nominale	Rated frequency	HZ	50/60
Fusibili ritardati	Delayed fuses	A	16
Livello temp. trasformatore di carica	Load transformer temperature level		F
Cl. isolamento trasformatore di carica	Load transformer insul. class		F
Termostato di sicurezza su trasformatore	Safety thermostat on transformer	°C	90
Termostato di sicurezza	Safety thermostat	°C	70
Lunghezza cavo torcia	Length and cross section of torch cable	mm/mmq	5000/25
Lunghezza cavo massa	Length and cross section of earth lead	mm/mmq	4000/25
Dimensioni ALU Spot Power 230 Evolution	Spot Power 230 e 400 dimensions	mm	240x465x295
Peso	Weight	Kg	21

## Dotazioni | Equipment

- Pistola puntatura alluminio, con precarica a molla regolabile
- 1 cavo per pistola
- 2 cavi massa
- 1 cassetta economica consumabili per alluminio art. CS072000
- 1 Gun for spotting on aluminium, with adjustable spring loading
- 1 torch cable
- 2 earthing cables
- 1 small consumables box to aluminium dent pulling item CS072000

## Dimensioni | Dimension

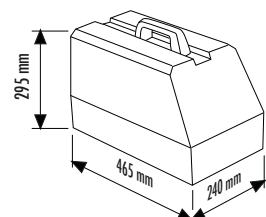



## TWIN SPOTTER 230 Art. 650SG



### Art. 650SG

Spotter combinato per tiro su acciaio + alluminio con un'unica macchina.

Riunisce le stesse caratteristiche dei modelli Spot Power 230 Volt Evolution + ALU Spot Power, in un'unica unità. E' una macchina ottimale per riparazione su vetture con lameriati 'misti' acciaio e alluminio. Riduce gli ingombri ed ottimizza i costi.

Combined spotter for dent pulling on steel + aluminium panels in a single machine. Combines the characteristics of the Spot Power 230 Volt Evolution + ALU Spot Power models in a single body, with an unique electronic control. Ideal for spotting on vehicles with mixed steel-aluminium panels. Saves space and optimises costs.

### Caratteristiche tecniche | Technical specifications

Potenza nominale al 50%	Rated power at 50%	KVA	Sn 3,5
Corrente sec. di corto circuito	Sec. short circuit current	KA	2800
Tensione secondaria	Secondary voltage	V	7
Capacità	Capacity		66 mF
Alimentazione	Single-phase power voltage	V	230
Frequenza nominale	Nominal frequency	HZ	50/60
Fusibili ritardati	Delayed fuses	A	16
Livello temp. trasformatore	Temperature level of power transformer		F
Cl. isolamento trasformatore	Power transformer insulation class		F
Termostato di sicurezza su connettori	Safety thermostat on cable connectors	°C	90°
Termostato di sicurezza	Safety thermostat	°C	70°
Lunghezza cavo torcia "ALU"	Length and cross section of torch cable "ALU"	mm/mm <sup>2</sup>	5000/25
Lunghezza cavo massa "ALU"	Length and cross section of earth lead "ALU"	mm/mm <sup>2</sup>	4000/25
Lunghezza cavo torcia "FE"	Length and cross section of torch cable "FE"	mm/mm <sup>2</sup>	2500/50
Lunghezza cavo massa "FE"	Length and cross section of earth lead "FE"	mm/mm <sup>2</sup>	2000/50
Dimensioni TWIN SPOTTER	TWIN SPOTTER dimensions	mm	320x470x240
Peso	Weight	Kg	21

### Dotazioni | Equipment

#### Per acciaio

- Martello completo di elettrodo puntatura e calde
- 2 cavi
- 1 massa rapida
- 1 cassetta economica consumabili per spotter ferro art. CS071100

#### Per alluminio

- 1 pistola puntatura
- 3 cavi
- 1 cassetta economica consumabili per alluminio art. CS072000

#### For steel

- 1 Gun with slide hammer with electrodes (1 spoting, 1 x shrinking)
- 2 cables
- 1 quick earth electrode
- 1 small consumables box to steel dent pulling item CS071100

#### For aluminium

- 1 Gun for spoting on aluminium, with adjustable spring loading
- 3 cables
- 1 small consumables box to aluminium dent pulling item CS072000

### Dimensioni | Dimension

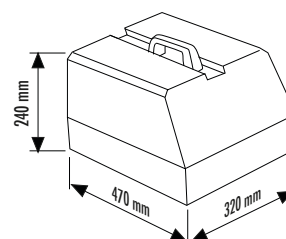



# CARRELLI | TROLLEY SPOT POWER Art. 660 - 660B - Art.661 - Art. 670



Art. 660 | Carrello Economy  
Economy Trolley

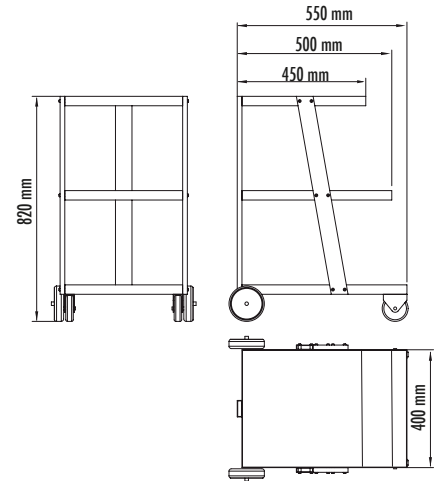

Art. 661  
con cassetto  
with drawer



Art. 660B

Art. 660B  
Art. 661

I carrelli comprendono:

- Art. D6300200 - Tappetino gomma 1 pz
- Art. D6300210 - Tappetino gomma 1 pz
- Art. D6300220 - Tappetino gomma 1 pz
- Art. 06500100 - Ganci semplici 3 pz
- Art. 06500200 - Ganci doppi 6 pz
- Art. 06500550 - Gancio e supporto per traversa

Trolleys include :

- Item D6300200 - Rubber mat 1 pc
- Item D6300210 - Rubber mat 1 pc
- Item D6300220 - Rubber mat 1 pc
- Item 06500100 - Hook, simple, 3 pc
- Item 06500200 - Hook, double 6 pcs
- Item 06500550 - Hook and support for crossbar

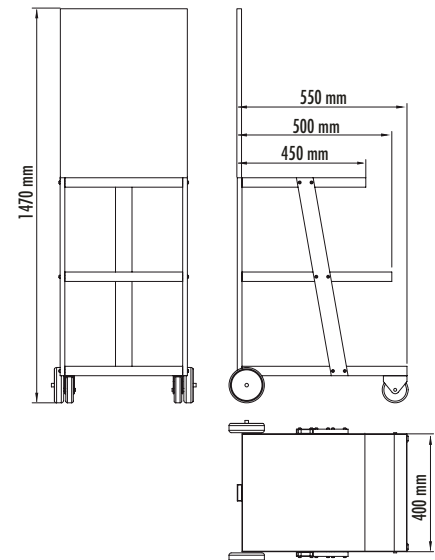

Art. 670

Carrello per Spotter, comprende:

- Art. D6300000 - Tappetini Millerighe 3 pz
- Art. 06500100 - Ganci semplici 7 pz
- Art. 06500200 - Ganci doppi 3 pz

Trolley for spotter, with:

- Item D6300000 - Rubber mats, 3 pcs
- Item 06500100 - Hook, simple, 7 pcs
- Item 06500200 - Hook, double 3 pcs

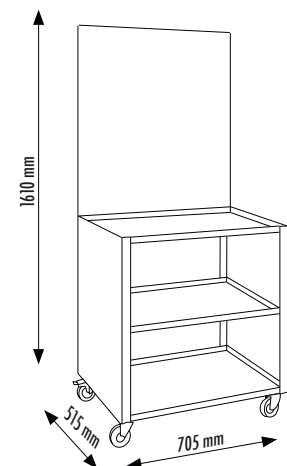



## KIT SPOT POWER STEEL Art. 810SG



### Dotazioni | Equipment

#### Art. 810SG - Kit completo di:

- Art. EVO 230 Spot Power 230
- Art. 670 - Carrello
- Art. D6300000 - Tappetini Millerighe 3 pz
- Art. -0100 - Ganci semplici 7 pz
- Art. 06500200 - Ganci doppi 3 pz
- Art. 750 - Traversa di tiro con piedi e tiranti (L=850 mm)
- Art. 710 - Traversa senza piedi e tiranti (L=1180 mm)
- Art. 173 - Confezione 50 pz fili ondulati
- Art. 175 - Leva di tiro POWER LIFT
- Art. 177/A - Elettrodo estrattore con peso estrattore
- Art. 179 - Pistola estrattore manuale FALCON
- Art. 07501100 - Conf 50 pz rondelle asolate diritte
- Art. 07502100 - Conf 50 pz rondelle asolate piegate
- Art. CS071100 - Cassetta economica consumabili per spotter ferro

#### Item 810 SG - Complete set with:

- Item EVO 230 Spot Power 230
- Item 670 - Trolley
- Item D6300000 - Rubber mats, 3 pcs
- Item 06500100 - Hook, simple, 7 pcs
- Item 06500200 - Hook, double 3 pcs
- Item 750 - Dent Lifter complete with crossbar 850 mm
- Item 710 - Long crossbar alone to Dent Lifter (L=1180 mm)
- Item 173 - Pack 50 pcs wiggly wires
- Item 175 - POWER LIFT pulling lever
- Item 177/A - Long electrode with sliding weight
- Item 179 - FALCON hand puller
- Item 07501100 - 50 pcs welding washers straight
- Item 07502100 - 50 pcs welding washers twisted
- Item CS071100 - Small consumables box to steel dent pulling





## KIT SPOT POWER ALU Art. 840SG



Art. 840SG

Kit completo di carrello, accessori e Alu Spotter 230 Evolution, per lamierati di alluminio.

Dotazione di speciali attrezzature per la riparazione di piccole ammaccature sui lamierati di alluminio, che dovrebbero altrimenti essere completamente sostituiti con notevoli problematiche di riassetto. Il Kit ALU consente riparazioni professionali veloci ed economiche garantendo la conservazione delle caratteristiche strutturali del veicolo nuovo.

Complete kit with Trolley, accessories and Alu Spot Power for dent repair on aluminium panels.

Dedicated equipment Kit for the repair of small dents on aluminum sheets, that would otherwise be completely replaced with serious issues concerning reassembly techniques. The ALU Kit allows quick, professional and economic repair ensuring the preservation of the original characteristics of the new vehicle.

### Dotazioni | Standard Equipment

- Art. 640SG - ALU Spot Power 230 Evolution
- Art. 670 - Carrello grande senza accessori
- Art. D6300000 - Tappetini Millerighe 3 pz
- Art. 06500100 - Ganci semplici 7 pz
- Art. 06500200 - Ganci doppi 3 pz
- Art. 750 - Traversa di tiro con piedi e tiranti (L=850 mm)
- Art. 710 - Traversa senza piedi e tiranti (L=1180 mm)
- Art. 740 - Mini traversa con piedi, tirante e 4 ganci (L=400 mm)
- Art. CS072100 - Cassetta professionale consumabili per Alu Spotter
- Art. 215 - Kit martelli in alluminio
- Art. C7501100 - Minimerigliatrice
- Item 640SG - ALU Spot Power 230 Evolution
- Item 670 - Tool trolley large
- Item D6300000 - Rubber mats 3 pcs
- Item 06500100 - Hook, simple, 7 pcs
- Item 06500200 - Hook, double 3 pcs
- Item 750 - Dent Lifter complete with crossbar 850 mm
- Item 710 - Long crossbar alone to Dent Lifter (L=1180 mm)
- Item 740 - Mini Dent Lifter with supports, puller and 4 hooks (L=400 mm)
- Item CS072100 - Professional consumable box for Aluminium spotter
- Item 215 - Kit Aluminium hammer
- Item C7501100 - Mini air grinder

### Dimensioni | Dimension

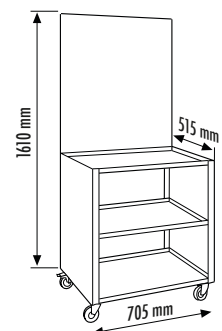





## CARRELLO | TROLLEY Art. 850



### Dotazioni | Equipment

Art. 850 - Kit completo di:

- Art. 670 - Carrello
- Art. D6300000 - Tappetini Millerighe 3 pz
- Art. 06500100 - Ganci semplici 7 pz
- Art. 06500200 - Ganci doppi 3 pz
- Art. 750 - Traversa di tiro con piedi e tiranti (L=850 mm)
- Art. 710 - Traversa senza piedi e tiranti (L=1180 mm)
- Art. 173 - Confezione fili ondulati (50 pz.)
- Art. 175 - Leva di tiro POWER LIFT
- Art. 177/A - Elettrodo estrattore con peso estrattore
- Art. 179 - Pistola estrattore manuale FALCON
- Art. 07501100 - Conf 50 pz rondelle asolate diritte
- Art. 07502100 - Conf 50 pz rondelle asolate piegate
- Art. CS071100 - Cassetta economica consumabili per spotter ferro

Item 850 - Complete set with:

- Item 670 - Trolley
- Item D6300000 - Rubber mats, 3 pcs
- Item 06500100 - Hook, simple, 7 pcs
- Item 06500200 - Hook, double 3 pcs
- Item 750 - Dent Lifter complete with crossbar 850 mm
- Item 710 - Long crossbar alone to Dent Lifter (L=1180 mm)
- Item 173 - Pack 50 wiggly wires
- Item 175 - POWER LIFT pulling lever
- Item 177/A - Long electrode with sliding weight
- Item 179 - FALCON hand puller
- Item 07501100 - 50 pcs welding washers straight
- Item 07502100 - 50 pcs welding washers twisted
- Item CS071100 - Small consumables box to steel dent pulling

### Dimensioni | Dimensions





## CARRELLO ECONOMY | ECONOMY TROLLEY Art. 855



### Dotazioni | Equipment

#### Art. 855 - Kit completo di:

- Art. 660B - Carrello Economy Bryan
- Art. D6300200 - Tappetino gomma 1 pz
- Art. D6300210 - Tappetino gomma 1 pz
- Art. D6300220 - Tappetino gomma 1 pz
- Art. 06500100 - Ganci semplici 1 pz
- Art. 06500200 - Ganci doppi 6 pz
- Art. 06500550 - Gancio e supporto per traversa
- Art. 740 - Mini traversa con piedi, tirante e 4 ganci (L=400 mm)
- Art. 750 - Traversa di tiro con piedi e tiranti (L=850 mm)
- Art. 215 - Kit martelli in alluminio
- Art. CS072000 - Cassetta economica consumabili per alluminio

#### Item 855 - Complete set with:

- Item 660B - Economy Trolley Bryan
- Item D6300200 - Rubber mat 1 pc
- Item D6300210 - Rubber mat 1 pc
- Item D6300220 - Rubber mat 1 pc
- Item 06500100 - Hook, simple, 1 pc
- Item 06500200 - Hook, double 6 pcs
- Item 06500550 - Hook and support for crossbar
- Item 740 - Mini Dent Lifter with supports, puller and 4 hooks (L=400 mm)
- Item 750 - Dent Lifter complete with crossbar 850 mm
- Item 215 - Kit Aluminium hammer
- Item CS072000 - Small consumables box to aluminium dent pulling

### Dimensioni | Dimension

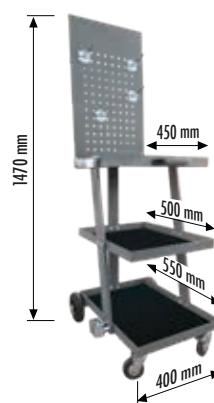



## CARRELLO ECONOMY | ECONOMY TROLLEY Art. 860



### Dotazioni | Equipment

#### Art. 860 - Kit completo di:

- Art. 660B - Carrello Economy Bryan
- Art. D6300200 - Tappetino gomma 1 pz
- Art. D6300210 - Tappetino gomma 1 pz
- Art. D6300220 - Tappetino gomma 1 pz
- Art. 06500100 - Ganci semplici 1 pz
- Art. 06500200 - Ganci doppi 6 pz
- Art. 06500550 - Gancio e supporto per traversa
- Art. 750 - Traversa di tiro con piedi e tiranti (L=850 mm)
- Art. 173 - Confezione fili ondulati (50 pz.)
- Art. 175 - Leva di tiro POWER LIFT
- Art. 179 - Pistola estrattore manuale FALCON
- Art. 07501100 - Conf 50 pz rondelle asolate diritte
- Art. CS071100 - Cassetta economica consumabili per spotter ferro

#### Item 860 - Complete set with:

- Item 660B - Economy Trolley Bryan
- Item D6300200 - Rubber mat 1 pc
- Item D6300210 - Rubber mat 1 pc
- Item D6300220 - Rubber mat 1 pc
- Item 06500100 - Hook, simple, 1 pc
- Item 06500200 - Hook, double 6 pcs
- Item 06500550 - Hook and support for crossbar
- Item 750 - Dent Lifter complete with crossbar 850 mm
- Item 173 - Pack 50 wiggly wires
- Item 175 - POWER LIFT pulling lever
- Item 179 - FALCON hand puller
- Item 07501100 - 50 pcs welding washers straight
- Item CS071100 - Small consumables box to steel dent pulling

### Dimensioni | Dimensions

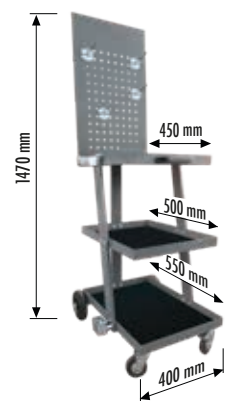





## TWIN WORK STATION Art. 870SG



TWIN WORK STATION, esclusività STANZANI, è l'unico sistema che concentra, in un solo mobile, tutta l'attrezzatura e la tecnologia utile alla riparazione di lamierati in Acciaio o Alluminio. Completa di ogni accessorio, la stazione è dotata di un solo SPOTTER disposto su tavola rotante, per posizionarsi comodamente sul lato di lavoro:

- Ingombri ridotti
- Accessori FE e AL ordinatamente classificati e separati, per evitare contaminazione fra i metalli
- Prese elettriche e attacchi aria integrati

The exclusive Twin Work Station Stanzani combines in a single tool trolley all the equipment and technology for the dent repair operations on steel and aluminium panels. The Twin Work Station is fully equipped also with an unique TWIN SPOTTER, assembled on turning table, so be easily positioned on different working locations:

- Very strong and compact
- Accessories for steel and aluminium stored separately to prevent contact and contamination
- Built in electric sockets and air connections

### Dotazioni | Equipment

- Art. 650SG Twin Spotter 230 Evolution
- Art. 680 - Carrellone Work Station
- Art. D6300100 - Tappetini Millerighe 3 pz
- Art. 06500100 - Ganci semplici 10 pz
- Art. 06500200 - Ganci doppi 5 pz

#### Accessori per acciaio:

- Art. 750 - Traversa di tiro con piedi e tiranti (L=850 mm)
- Art. 710 - Traversa senza piedi e tiranti (L=1180 mm)
- Art. 173 - Confezione fili ondulati, 50 pz
- Art. 175 - Leva di tiro POWER LIFT
- Art. 177/A - Elettrodo estrattore con peso estrattore
- Art. 179 - Pistola estrattore manuale FALCON
- Art. 07501100 - Confezioni rondelle asolate diritte, 50 pz
- Art. 07502100 - Confezioni rondelle asolate piegate, 50 pz
- Art. CS071100 - Cassetta economica consumabili per spotter ferro

#### Accessori per alluminio:

- Art. 740 - Mini traversa con piedi, tirante e 4 ganci (L=400 mm)
- Art. CS072100 - Cassetta professionale consumabili per Alu Spotter
- Art. 215 - Kit martelli in alluminio
- Art. C7501100 - Minimerigliatrice

- Item 650 SG Twin Spotter 230 Evolution
- Item 680 - Work Station Trolley
- Item D6300100 - Rubber mats, 3 pcs
- Item 06500100 - Hook, simple, 10 pcs
- Item 06500200 - Hook, double 5 pcs

#### Accessories for steel repair

- Item 750 - Dent Lifter complete with crossbar 850 mm
- Item 710 - Long crossbar alone to Dent Lifter (L=1180 mm)
- Item 173 - Pack 50 wiggly wires
- Item 175 - POWER LIFT pulling lever
- Item 177/A - Long electrode with sliding weight
- Item 179 - FALCON hand puller
- Item 07501100 - 50 pcs welding washers straight
- Item 07502100 - 50 pcs welding washers twisted
- Item CS071100 - Small consumables box to steel dent pulling

#### Accessories for aluminium repair

- Item 740 - Mini Dent Lifter with supports, puller and 4 hooks (L=400 mm)
- Item CS072100 - Professional consumable box for Aluminium spotter
- Item 215 - Kit Aluminium hammer
- Item C7501100 - Mini air grinder

### Dimensioni | Dimension

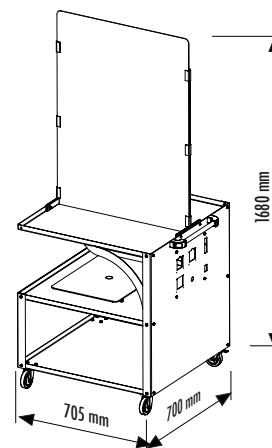



## ACCESSORI PER ACCIAIO | STEEL ACCESSORIES

Art. 710 | Traversa di tiro extra lunga in alluminio (L= 1180 mm), solo traversa  
Long crossbar alone to Dent Lifter (L=1180 mm)



Art. 750 | Traversa di tiro completamente in alluminio (L= 850 mm)  
Completa di traversa, piedi, tirante e n. 2 artigli a 4 e 6 ganci, n° 2 ventose  
Dent Lifter, fully in aluminium (L=850mm).  
Complete with crossbar, supports, pulling handle, 2 claws with 4 and 6 hooks, 2 suction cups



Art. 175 | Power Lift



Art. 175M | Power Lift  
Versione magnetica  
Magnetic version

Art. 06520000 | Supporto angolare  
Angle plate



Art. 06520100 | Artiglio di tiro a 5 ganci  
Pull claw with 5 hooks

Art. 06520200 | Artiglio di tiro a 7 ganci  
Pull claw with 7 hooks

Art. 177A | Elettrodo estrattore con peso battente e punta intercambiabile  
Long electrode with sliding weight, interchangeable tip



Art. 179 | Falcon, pistola estrattore manuale, completa di 3 elettrodi (puntatura/calde collegamento a spotter e/o pistola)  
Falcon, manual pulling gun, with 3 electrodes (spot/welding/shrinking/connection to spotter and/or spot gun)



Art. 170 | Artiglio di tiro, a 9 ganci.  
Pull claw with 9 hooks



Art. D1800900 | Elettrodo per puntatura rondelle asolate  
Electrode for spotting of oval washers



Art. 06500300 | Asta in acciaio L.200 mm.  
Steel rod L. 200 mm



Art. 06500400 | Asta in acciaio L.380 mm.  
Steel rod L. 380 mm

Art. 06500350 | Asta in acciaio esagonale L.200  
Hexagonal steel rod L.200



Art. 06500450 | Asta in acciaio esagonale L.300  
Hexagonal steel rod L.300

Art. 171 | Martello di tiro per artiglio, forza battente 2 Kg  
Slide hammer for pull claw, slide weight 2 kg





## ACCESSORI PER ALLUMINIO | ALUMINIUM ACCESSORIES

**Art. 740**  
Mini traversa con piedi fissi, Completa di traversa, piedi, tirante a 4 ganci (L= 400 mm)  
Mini Dent Lifter with supports, puller and 4 hooks (L= 400 mm)



**Art. 215**  
Kit martello in alluminio  
Kit aluminium hammer



**Art. 175 - Power Lift**



**Art. C7501100**  
Mini smerigliatrice pneumatica (pz.1)  
Mini air grinder (pz.1)



## CASSETTE CONSUMABILI PER SPOT POWER SYSTEM | CONSUMABLE BOXES TO SPOT POWER SYSTEM

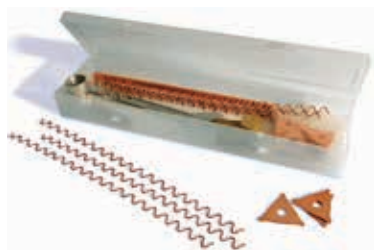

**Art. CS071100**  
Cassetta economica consumabili per spotter ferro completa di  
Small consumables box to steel dent pulling complete with:  
00172D00 - Fili ondulati (conf. 10 pz) / Wiggly wire  
CS002000 - Confezione rondelle ramate a tre punte sp. 2mm  
Pack 3-angled copper plated washers thik. 2mm  
CS034000 - Chiave esagonale 27 / Hex wrench  
CS036000 - Elettrodo al carbone (Ø10 x 300)  
Carbon electrode (Ø10 x 300)  
CS039000 - Elettrodo per rondelle a 3 punte M.14  
M.14 electrode to 3-angled washers  
CS049000 - Scatola in plastica / plastic box  
CS050000 - Sostegno magnetico per filo ondulato  
Magnetic holder to wiggly wires  
D1800100 - Elettrodo a punta per filo ondulato  
Fine tip electrode to wiggly wire



**Art. CS072000**  
Cassetta economica consumabili per alluminio completa di  
Small consumables box to aluminium dent pulling complete with:  
07500100 - 10 pz golfare m4 / 10 x threaded pull eye m4  
07500300 - 100 pz perni fil. m4\*15 AlSi  
100 x stud bolts m4\*15 AlSi  
07500400 - 100 pz perni fil. m4\*15 al.mg3  
100 x stud bolts m4\*15 al.mg3  
C2300080 - Contenitore bivalve 140x75x30  
Container 2 valves 140x75x30



**Art. CS072100**  
Cassetta professionale consumabili per Alu Spotter  
Professional consumable box for Aluminium spotter:  
07500050 - 10 pz golfare m6 /10 x threaded pull eye m6  
07500100 - 10 pz golfare m4/10 x threaded pull eye m4  
07500150 - 10 pz golfare m5/10 x threaded pull eye m5  
07500300 - 100 pz perni fil. m4\*15 AlSi  
100 x stud bolts m4\*15 AlSi  
07500400 - 100 pz perni fil. m4\*15 al.mg3  
100 x stud bolts m4\*15 al.mg3  
C2300060 - Contenitore bivalve 295\*70\*35 transp./174  
Container 2 valves 295\*70\*35 transp./174  
CS048200 - Elettrodo m5 x pistola alu  
Electrode m5 for al welding gun  
CS048400 - Elettrodo m6 x pistola alu  
Electrode m6 for al welding gun





## CONSUMABILI PER SPOT POWER SYSTEM | CONSUMABLES TO SPOT POWER SYSTEM



Art. 172 30 pz/pcs  
Art. 173 50 pz/pcs  
Art. 174 100 pz/pcs  
Confezione fili ondulati per saldatura  
Wiggly wires packages



Art. D1800100 1 pz/pcs  
Elettrodo a punta per filo ondulato  
Fine tip electrode to wiggly wire



Art. CS050000 Sostegno magnetico per filo ondulato  
Magnetic holder for wiggly wires



Art. 07501000 10 pz/pcs  
Art. 07501100 50 pz/pcs  
Confezione rondelle asolate ramate diritte  
Pack oval washer plated straight



Art. 07500400 100 pz/pcs M4X15  
Confezione prigioniero filettato in AL.Mg3  
Pack stud bolts in AL.Mg3



Art. 07500300 100 pz/pcs  
Confezione prigioniero filettato M 4 x 15 AlSi  
Pack aluminium Silicon stud bolts in AlSi M 4 x 15



Art. 07500100 10 pz/pcs M4  
Art. 07500050 10 pz/pcs M6  
Art. 07500150 10 pz/pcs M5  
Confezione golfare con filetto per saldatura in alluminio e tasselli colla filettati  
Pack threaded pull eye, for aluminium and glue pads with threaded pin.



Art. CS002000 20 pz/pcs  
Art. CS003000 50 pz/pcs  
Art. CS004000 100 pz/pcs  
Art. CS005000 1000 pz/pcs  
Confezione rondelle ramate a tre punte  
Pack 3-angled copper plated washers



Art. CS039000 1 pz/pcs  
Supporto rondelle 3 punte M.14  
M.14 electrode for 3-angled washers



Art. 07502000 10 pz/pcs  
Art. 07502100 50 pz/pcs  
Confezione rondelle asolate ramate piegate  
Pack oval washer plated twister



Art. D1800900 1 pz/pcs  
Elettrodo per puntatura rondelle asolate  
Electrode for spotting of oval washers



Art. CS001000 (ø 2,5 x 50) 100 pz/pcs  
Art. CS001100 (ø 2,5 x 50) 500 pz/pcs  
Confezione spine ramate  
Pack copper plated nails



Art. CS036000 1 pz/pcs  
Elettrodo al carbone (Ø 10 x 300)  
Carbon electrode (Ø10 x 300)  
Art. CS037000 5 pz/pcs  
Confezione elettrodo al carbone (Ø 10 x 300)  
Pack carbon electrode (Ø10 x 300)



Art. 06500300 Asta in acciaio L.200 mm.  
Steel rod L. 200 mm



Art. 06500400 Asta in acciaio L.380 mm.  
Steel rod L. 380 mm



Art. 06500350 Asta in acciaio esagonale L.200  
Hexagonal steel rod L.200

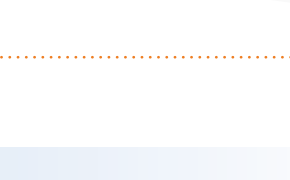

Art. 06500450 Asta in acciaio esagonale L.300  
Hexagonal steel rod L.300



# glass line

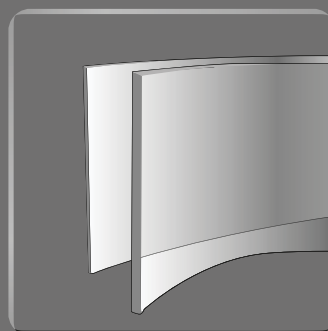

Particolari lavorazioni di carrozzeria richiedono attrezzature o strumenti progettati per resistere a pesanti sollecitazioni strutturali e per coadiuvare il lavoro dell'operatore, come ad esempio Willy, l'esclusivo manipolatore studiato dalla Stanzani per consentire lo smontaggio/montaggio di vetri, portiere, pannelli di autobus e camion di medie e grosse dimensioni.

---

Special bodywork requires special tools or equipment designed to withstand heavy structural stress and also to assist the operator such as, for example, Willy the exclusive manipulator studied by Stanzani to allow the disassembly/assembly of windows, doors, panels of medium- and large-sized buses and trucks.



## TERENCE Art. 124V



### Art. 124V

Cavalletto robusto per l'appoggio di vetri parabrezza di grandi dimensioni. La catena di fissaggio consente un'apertura massima del supporto di 1000 mm. I bracci di appoggio sono dotati di protezione in gomma piuma. Il supporto è necessario per le lavorazioni dei vetri. Viene fornito montato e pronto all'uso.

Study panel rest for the support of long size windscreens. Thanks to the chain, the support can be open by a maximum 1000 mm. The support arms feature foam rubber protection. Support is necessary for the complete processing of the glass. Supplied assembled and ready for use.



Caratteristiche tecniche Technical specifications		124V
Materiale Raw Material		ferro verniciato coated iron
Dimensioni max ingombro Max working dimensions	mm	800 x 1250 H
Regolazione altezza Height adjustment		mediante catenella by means of chain
Protezione tubi Protection to support arms		gomma piuma foam rubber
Peso Weight	Kg	9,7



## RASTRELLIERA VERTICALE | VERTICAL RACK Art. 313



### Art. 313

#### Rastrelliera verticale.

Consente lo stoccaggio rapido e razionale dei parabrezza. I bracci portanti sono rivestiti di morbida gomma. Solo per uso singolo, senza ruote. La rastrelliera viene fornita completamente smontata.

#### Vertical rack.

Strong rack for rational storage of car windscreen. The supporting arms are covered with soft foam protection. To be used single without castors. The bumper rack is supplied completely dismantled to reduce transport costs.

Caratteristiche tecniche Technical specifications		313
Materiale Row Material		tubolare verniciato con protezione gommapiuma tubular painted steel, with foam protections
Max capacità stoccaggio Max Storage capacity		4 parabrezza 4 windscreens
Larghezza Jaw width	mm	1090
Altezza Height	mm	2140
Profondità bracci Profondità bracci	mm	1000
Peso Weight	Kg	42,2



## WILLY Art. 9900



**Art.9900**  
WILLY è una attrezzatura per la manipolazione di vetri, portiere e pannellature per automezzi di grandi dimensioni e veicoli industriali. WILLY consente di ridurre il personale impiegato per operazioni di manutenzione sui veicoli industriali. Ad esempio un solo operatore può prelevare un parabrezza di un bus dal magazzino, posizionarlo in prossimità del veicolo, stendere il mastice e in pochi secondi applicare il vetro nella giusta posizione, grazie ad un attuatore orizzontale di Willy, che lo tiene saldamente premuto, fino a che il mastice non va in presa.

### Punti di forza di Willy:

- OMOLOGATA C E
- l'alimentazione autonoma mediante batteria a 24 volt lo rende completamente indipendente da alimentazione elettrica e pertanto utilizzabile ovunque.
- il quadro elettrico è munito di presa per ricarica batterie e indicatore dello stato di carica
- dotato di un pratico telecomando che permette all'operatore di effettuare ed osservare da vicino tutte le operazioni, in massima sicurezza e senza fatica.
- un potenziometro sul comando consente la regolazione della velocità di ogni movimento
- 4 ruote, di cui 2 piroettanti con freno, consentono un posizionamento agevole e preciso
- il sistema di sollevamento a parallelogramma garantisce una perfetta stabilità durante le operazioni di lavoro.
- gli attuatori della testata di ancoraggio la orientano in tutte le direzioni molto lentamente e con la massima precisione e sicurezza.
- le ventose di ancoraggio sono regolabili per garantire una perfetta presa ed un miglior bilanciamento dell'oggetto movimentato.

WILLY is designed to handle glazing, doors and panels of large and industrial vehicles, reducing the number of operators required for maintenance operations on industrial vehicles.

For example, a single operator can take a bus windscreen from the warehouse, position it close to the vehicle, apply the adhesive and, in just a few seconds, fit the glazing in the correct position, thanks to a horizontal actuator that keeps it firmly pressed, until the adhesive has taken effect.

### WILLY's strong points:

- C E APPROVED
- the 24 V independent battery supply makes it completely independent of mains power and therefore usable everywhere.
- the electrical panel is provided with inlet socket for batteries recharging and status indicator
- is provided with a remote control so to perform and observe all operations close up, yet in total safety and with the utmost ease for the operator
- a potentiometer is provided on the control panel for speed adjusting of each movement
- thanks to the four castor wheels, 2 of which swiveling with brake, WILLY can be positioned very easily and precisely
- the parallelogram lifting system ensures perfect stability during operation
- thanks to the anchoring actuators, WILLY's head can be positioned in all directions, very slowly and with utmost precision and safety.
- the anchoring suction cups are adjustable to ensure perfect grip and the better balancing of the object being handled.



## WILLY Art. 9900

### Applicazioni | Use mode

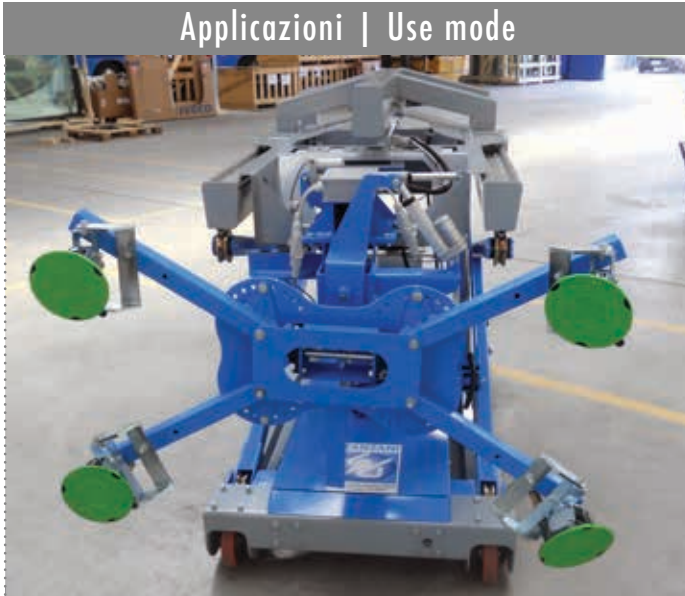

Caratteristiche tecniche Technical specifications		9900
Materiale Row Material		acciaio verniciato a polvere apossida steel powder coated
Alimentazione a batterie ricaricabili Powered by rechargeable batteries		24 Volt CC/DC
Portata max Max lifting capacity	kg	300
Peso Weight	kg	400

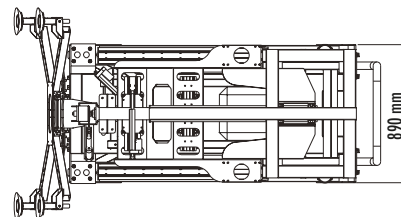
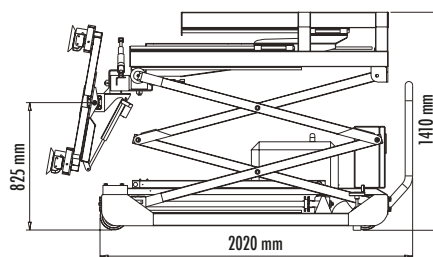
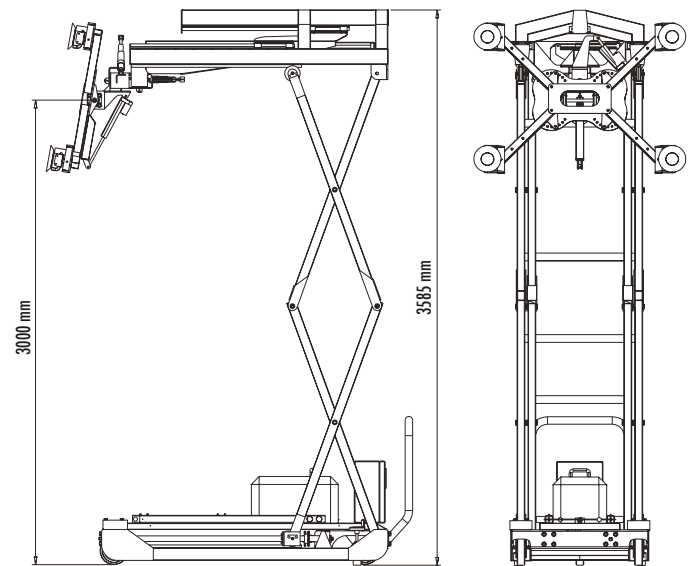



## WILLY LIGHT Art. 9930



Willy light, versione semplificata del modello base (Willy Art. 9900), si utilizza per la manipolazione di vetri, portiere e pannellature per automezzi di grandi dimensioni e veicoli industriali con l'ausilio di un muletto, agevolando di fatto il lavoro degli addetti alla manutenzione.

Un solo operatore può prelevare un parabrezza o un vetro dal magazzino, posizionarlo in prossimità del veicolo, eseguire le varie operazioni e in pochi secondi applicare il vetro nella sede.

La stabilità del manipolatore è garantita dal sistema costruttivo che mantiene la stessa manovrabilità del sistema gemello (Willy Art. 9900), con manipolatore e presa mediante ventose, basculamento, inclinazione e rotazione.

Willy light, a simplified version of the basic model (Willy Item 9900), is used for handling glass, doors and panels for large motor vehicles and industrial vehicles with the use of a lift truck, assisting the work of maintenance workers.

A single operator can pick up a windscreen or other glass pane from the warehouse, position it close to the vehicle, carry out the various operations and fit the glass in place in just a few seconds.

The stability of the handler is guaranteed by the construction system, which features the same manoeuvrability as the twin system (Willy Item 9900), with handler and suction cup grip, swivel, tilt and rotation.



## WILLY Art. 9930

### Applicazioni | Use mode



Caratteristiche tecniche Technical specifications		9930
Materiale Row Material		acciaio verniciato a polvere apossida steel powder coated
Alimentazione a batterie ricaricabili Powered by rechargeable batteries		24 Volt CC/DC
Portata max Max lifting capacity	kg	300
Lunghezza Length	mm	1550
Larghezza Width	mm	800
Altezza posteriore Rear height	mm	900
Altezza anteriore Front height	mm	1200
Altezza anteriore con bracci in alto Front height with arms up	mm	1500
Peso Weight	kg	260





# garage line



Una linea di prodotti, accessori e attrezzature specifici per auto officine o carrozzerie per lavorare in sicurezza o mantenere in ordine le aree di lavoro. Alcuni accessori sono particolarmente indicati anche per privati che disponendo di spazi adeguati all'interno del loro garage desiderano avere un carrello porta hard top di sicurezza o stoccare le gomme ordinatamente.

---

A line of products, accessories and equipment-specific auto repair shop or car bodies to work safely or maintain order in the working areas. Some accessories are also particularly suited for individuals who already have adequate space in their garage wish to have a carriage door hard top safety or neatly store your tires.



## MOTOGO TANDEM Art. 114T



### Art. 114T

Carrello parking di grande portata e praticità per moto con cavalletto laterale. Le ruote snodabili ma con dispositivo autofrenante, consentono di muovere agevolmente la moto.

Wide-ranging parking trolley, convenient for motorcycles with side stands. The wheels, articulated but fitted with self-braking device, allow maneuvering the bike easily.

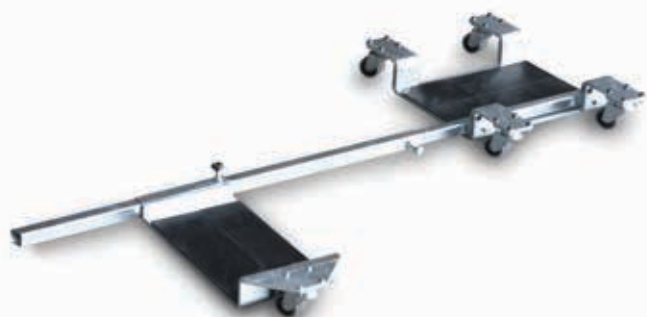

Caratteristiche tecniche Technical specifications		114T
Materiale Row Material		acciaio steel
Portata max Max lifting capacity	kg	500
Peso Weight	Kg	24



## PEDANA ALLUMINIO | ALUMINIUM LADDER Art. 305A



### Art. 305A

Pedana in alluminio regolabile in altezza e lunghezza, stabile, facilmente trasportabile.

Aluminium platform, adjustable in height and length, stable, easy to carry.



Caratteristiche tecniche Technical specifications		305A
Materiale Raw Material		alluminio aluminium
Portata max Max lifting capacity	kg	150
Lunghezza min/max Min/max. length	mm	da 1090 a 1750 from 1090 to 1750
Larghezza Width	mm	300
Altezza min/max Max/Min. height	mm	da 522 a 905 from 522 to 905
Approvazione Approval		EN131
Peso Weight	Kg	15



## HARD TOP Art. 311HT



### Art. 311HT

Carrello regolabile porta Hard Top. Leggero e robusto, fornito di elementi protettivi per mantenere l'integrità dell'hard top. Dotato 4 pratiche ruote girevoli 2 delle quali con freno.

Adjustable cart holder hard top. Lightweight but strong, adjustable, fitted with protective elements to maintain the integrity of the hard top. Equipped with 4 practical swivel casters 2 of them with brakes.



Caratteristiche tecniche Technical specifications		311HT
Materiale Raw Material		acciaio steel
Altezza max Max height	mm	2100
Larghezza max Max. Width	mm	1700
Larghezza min Min. width	mm	1100
Profondità max Width Max	mm	1550
Profondità min Min depth	mm	960
Peso Weight	Kg	18

## CARRELLO VERNICIATURA SERBATOIO | TANK COATING TROLLEY Art. 350

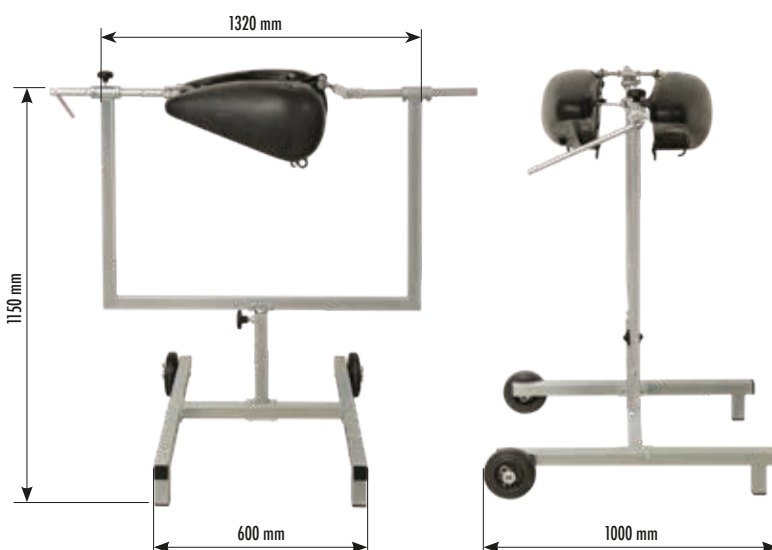

### Art. 350

Ideale per la preparazione, la verniciatura e la lucidatura di ogni tipo di serbatoi per moto. Viene fornito con attacchi standard che consentono, con applicazioni semplici, il fissaggio del serbatoio per le lavorazioni. Il carrello è dotato di ruote in gomma adatte al trasporto nelle cabine di verniciatura.

Ideal for preparing, coating and polishing any type of motorcycle tank. Supplied with standard fittings to enable the tank to be easily secured to the trolley.

The trolley is fitted with rubber wheels for moving into the paint booth.

Caratteristiche tecniche Technical specifications		350
Materiale Material		acciaio steel
Peso Weight	Kg	17



## SUPPORTO VERNICIATURA CASCO | HELMET PAINTING HOLDER Art. 353



### Art. 353

Supporto indispensabile per il giusto posizionamento in piano di caschi di qualsiasi tipologia e dimensione. Ideale per effettuare lavori di serigrafia e verniciatura.

Essential for correctly positioning helmets of any size and type. Ideal for screen printing and painting.

Caratteristiche tecniche Technical specifications		353
Materiale Row Material		acciaio steel
Lunghezza Length	mm	200
Larghezza Width	mm	200
Altezza Max. Max. height	mm	280
Peso Weight	Kg	4,2



## TYREGO Art. 450



### Art. 450

Porta gomme. Pratico e compatto portagomme in tubolare, carrellato e regolabile per lo stoccaggio di 4 pneumatici di uguale dimensioni. Mantiene perfettamente compattate l'intero treno di gomme.

Tire holder. Compact and convenient tire holder in tubular, trolley and adjustable for vertical storage. It keeps perfectly the compacted set of tires.

Caratteristiche tecniche Technical specifications		450
Materiale Row Material		acciaio steel
Peso Weight	Kg	11,50

## Accessori | Accessories



Art. 06501100 | Piede appoggio  
Support feet



Art. 06501200 | Sovrapposizione  
orizzontale  
Horizontal overlapping



Art. 06501300 | Kit 4 ruote, di cui 2 con freno.  
Abbinabile con art. 06501100  
4 castor wheels kit, 2 of which  
with brake. Used with item  
06501100



Art. 06501400 | Sovrapposizione  
verticale  
Vertical overlapping



## DRILL BUMPER SENSOR Art. 460



### Art. 460

Punzoni per foratura paraurti per l'applicazione dei sensori di parcheggio.  
Kit formato da 6 punzoni (Ø 17-18-19-20-21-22 mm) e 1 punta di d.8 mm per praticare il foro nei paraurti, idonei alla foratura dei paraurti in plastica per l'applicazione di sensori. I punzoni (con testa esagonale da 13 mm) si possono utilizzare con un cricchetto a mano o con un avvitatore, effettuando il taglio dall'esterno verso l'interno anche su paraurti appena verniciati. La foratura non presenterà nessuna sbavatura. Per l'utilizzo dei punzoni è necessario realizzare un foro di centraggio nei paraurti di Ø 8 mm. La foratura consigliata dall'esterno verso l'interno non pregiudica l'eventuale verniciatura del paraurti.

Bumper drilling punches can be apply any type of parking sensor.  
Kit with 6 pieces d.17-18-19-20-21-22 mm and 1 helical point d. 8mm. Can be apply on any type of bumpers. After choose the size of punch tight a manual ratchet or a pneumatic tool. The part with the slinding punch and with the cutting part should be positioned outside the bumper. In few second you can obtain a hole of extreme precision without burr residue.  
The recommended drilling from the outside to the inside, doesn't affect the possible pre-painting of the bumper.

## Prodotti correlati | Related products



Art. 461 | Supporto verniciatura magnetico  
Painting magnetic support



## DRILL BUMPER SENSOR Art. 460L - 460M



Art. 460M



Art. 460L

Art. 460L - 13 punzoni/pieces (Ø 14-15-16-18.5-22.5-23-24-26-26.5-27-28-30-32)  
 Art. 460M - 19 punzoni/pieces (Ø 14-15-16-17-18-18.5-19-20-21-22-22.5-23-24-26-26.5-27-28-30-32)

### Art. 460L-460M

Punzoni per foratura paraurti per l'applicazione dei sensori di parcheggio. Kit formato da 13/19 punzoni o e 1 punta di d.8 mm per praticare il foro nei paraurti, ideali alla foratura dei paraurti in plastica per l'applicazione di sensori. I punzoni (con testa esagonale da 13 mm) si possono utilizzare con un cricchetto a mano o con un avvitatore, effettuando il taglio dall'esterno verso l'interno anche su paraurti appena verniciati. La foratura non presenterà nessuna sbavatura. Per l'utilizzo dei punzoni è necessario realizzare un foro di centraggio nei paraurti di Ø 8 mm. La foratura consigliata dall'esterno verso l'interno non pregiudica l'eventuale verniciatura del paraurti.

Bumper drilling punches can be apply any type of parking sensor.

Kit with 13/19 pieces and 1 helical point d. 8mm. Can be apply on any type of bumpers. After choose the size of punch tight a manual ratchet or a pneumatic tool. The part with the sliding punch and with the cutting part should be positioned outside the bumper. In few second you can obtain a hole of extreme precision without burr residue. The recommended drilling from the outside to the inside, doesn't affect the possible pre-painting of the bumper.

## Prodotti correlati | Related products



Art. 461 | Supporto verniciatura magnetico  
 Painting magnetic support



## SUPPORTO VERNICIATURA MAGNETICO | PAINTING MAGNETIC SUPPORT Art. 461



### Art. 461

Supporto con pinze per la verniciatura dei sensori di parcheggio.

Il magnete garantisce la perfetta adesione del supporto alla parete del forno, o ad un qualsiasi cavalletto utilizzato per la verniciatura.

Le dieci pinze di cui è dotato garantiscono di poter effettuare in una unica volta la verniciatura di tutti i sensori, oltre a poter sostenere altre piccole parti da verniciare.

Support with grippers for painting parking sensors.

The magnet ensure the perfect adhesion of the support to the wall of the oven, or to any stand used for painting.

The ten grippers which is fitted guarantee of being able to perform in a unique time the coating of all the sensors, besides being able to support other small parts to be painted.

## Prodotti correlati | Related products



### Art. 460

Punzoni per foratura paraurti per l'applicazione dei sensori di parcheggio  
Bumper drilling punches can be apply any type of parking sensor



## DOPPIA MORSA MAGNETICA | MAGNETIC DOUBLE CLAMP Art. 463



Art. 463

Doppia morsa magnetica

Supporto con pinze per la verniciatura. Attrezzo ideato per sostenere durante la verniciatura piccole parti di carrozzeria, quali: maniglie, calotte, specchietti retrovisori, ecc.

Grazie al sistema di bloccaggio a doppia morsa, garantisce la perfetta tenuta anche su piccole parti. Il magnete alla base, di grandi dimensioni, permette di posizionare facilmente l'attrezzo sulle pareti del forno o su cavalletti di sostegno pezzi.

Magnetic double clamp

Tool designed to support during painting small body parts, such as handle, caps, mirrors, etc. Thanks to the locking system double vise, it guarantees the perfect seal even on small parts.

The large magnet allows to easily position the tool on the oven walls or on support stands pieces.

### Prodotti correlati | Related products



Art. 309V | Carrello porta-paraurti  
Bumper stand



Art. 309A | Carrello salvaspazio  
Compact trolley









## CONDIZIONI GENERALI DI VENDITA

### 1. Prezzi

Salvo accordi particolari e specifici, i prezzi indicati nel listino in vigore e sulle conferme d'ordine si intendono al netto di IVA, spese di trasporto, imposta di bollo e di registro, diritti di dogana, per merce resa franco ns. stabilimento.

### 2. Termini di consegna

I termini di consegna si intendono sempre e soltanto approssimativi ed orientativi. Il Committente non può quindi in nessun caso chiedere la risoluzione del contratto ad esigere indennizzi da eventuali danni diretti od indiretti per il ritardo delle consegne. Gli ordini possono essere evasi in diverse spedizioni separate.

### 3. Spedizione

La spedizione della merce viene eseguita a rischio e pericolo del Committente che, al ricevimento della merce, deve verificare in presenza del trasportatore che l'imballo sia intatto, che non ci siano avarie, articoli mancanti o sostituzioni.

Ogni danno o perdita constatata deve essere segnalata immediatamente al corriere, firmando con riserva la bolla e confermando tale riserva tramite lettera raccomandata, spedita entro tre giorni dal ricevimento della merce.

L'inosservanza di questa clausola svincola l'impresa di trasporto dalle sue responsabilità. In mancanza di particolari istruzioni, la spedizione verrà effettuata con corriere scelto dalla Autoattrezzature Stanzani e il relativo onere sarà a carico del Committente.

### 4. Contestazioni

Eventuali contestazioni della merce oggetto della fornitura devono essere inoltrate alla ns. sede di Baricella a mezzo raccomandata entro cinque giorni dal ricevimento della merce. Qualunque contestazione in ordine alla tornitura non esime il Committente dall'obbligo del puntuale ed integrale pagamento del prezzo convenuto e delle rate del medesimo, come previsto dall'art. 1462 del C.C.

### 5. Pagamenti

I pagamenti dovranno pervenirci nei modi e nei termini pattuiti nella ns. conferma d'ordine. In caso di ritardato pagamento è ns. facoltà sospendere le forniture o annullare i rapporti in corso, ed addebitare al Committente gli interessi commerciali, che sono sin d'ora convenuti nella misura del 5% in più del tasso ufficiale di sconto annuo.

### 6. Diritto di proprietà

La Autoattrezzature Stanzani si riserva il diritto di proprietà sul materiale sino all'integrale avvenuto pagamento del prezzo ai termini dell'art. 1523 e sgg. C.C. La copertura del prezzo con cambiali o tratte non costituisce pagamento se non ad estinzione delle stesse. Il mancato pagamento, anche di una sola rata, semprechè superi l'ottava parte del pezzo, produrrà lo scioglimento del contratto con facoltà da parte della Autoattrezzature Stanzani di esigere l'immediata restituzione del materiale venduto.

### 7. Garanzie

La Autoattrezzature Stanzani garantisce i propri prodotti per un periodo di 12 mesi, a partire dalla data di fatturazione. Sono esclusi dalla garanzia danni dovuti a uso non corretto o non conforme dei prodotti, sforzi anomali, incuria, manipolazione irregolare e modifiche. Riparazioni, eseguite da terzi senza il ns. consenso scritto, nonché l'utilizzo di parti di ricambio non originali, esonerano lo Autoattrezzature Stanzani da qualsiasi responsabilità e pretesa derivante dall'obbligo di garanzia, nonché da risarcimento di spese di montaggio, smontaggio o risultanti da altri guasti. Si declina inoltre ogni responsabilità per danni diretti od indiretti, a persone o cose, che non siano oggetto della fornitura. Sia i prodotti coperti da garanzia, che al di fuori della garanzia devono esserci inviati in porto franco per le riparazioni.

### 8. Foro competente

Foro competente a luogo d'esecuzione è in ogni caso Bologna.

## GENERAL TERMS OF SALE

### 1. Prices

Except for particular and specific agreements, the prices indicated on our official price lists and order confirmations are to be meant as net of V.A.T., transport charges, stamp duty and registration tax, customs duties for goods delivered 'ex works'.

### 2. Delivery times

The delivery times are always and only to be meant as approximate and indicative. The Buyer cannot therefore in any case ask for agreement cancellation or claim compensations for possible direct or indirect damages due to a delivery delay. Orders can be shipped out in various, separate deliveries.

### 3. Goods travel

The goods travel at Buyer's risk. At receipt of goods, Buyer has to check, in presence of shipper, that packing is still in good order, that no damages occurred to goods, that no items are missing or substituted. Every damage or loss has to be immediately notified to shipper by signing the delivery slip with reservation. Such reservation is to be confirmed in writing by registered letter within 3 days after receipt of goods. The failed observance of this clause, frees the shipping company from any obligations.

Without special instructions, the shipment shall be carried out by transport means chosen by Autoattrezzature Stanzani and the relevant cost shall be for the Buyer's charge.

### 4. Contestations

Possible contestations of the supplied goods shall be addressed to our head office in Baricella by registered letter within 5 days from the goods receipt. Any contestation regarding the supply does not entitle the Buyer not to pay punctually and integrally the agreed price and its installments, as foreseen by art. 1462 C. C.

### 5. Payments

The payments shall be carried out in the ways and terms agreed in our order confirmation. In case of delayed payment Autoattrezzature Stanzani has the right to suspend the deliveries or cancel the existing relationship, and charge the Buyer with the commercial interests, agreed herewith as 5% higher than the official discount rate per year.

### 6. Property right

Autoattrezzature Stanzani holds the property right on the material up to the integral performed price payment according to the art. 1523 and foll. C. C. The price covering by bills or drafts is not to be meant as payment until their expiry. The failed payment even of a single installment if exceeding the price eighth part shall result in the agreement cancellation with the right by Autoattrezzature Stanzani to demand immediately the sold material return.

### 7. Guarantees

Autoattrezzature Stanzani guarantees the own products for a period of 12 months, starting from the invoicing date. Inconveniences due to incorrect or non conforming use, excessive strains, negligence, tampering and modifications are excluded from guarantee. Repairs, carried out by third parties, without our previous written agreement as well the use of non original spare parts, relieve Autoattrezzature Stanzani from any responsibility and claim coming from the guarantee, as well from reimbursement for assembling and disassembling expenses, or for subsequent damages. We are declining any responsibility for direct or indirect damages to persons and/or objects, not included in our delivery. All parts returned, to us for inspection and/or repair have to be sent to our factory free of transport charge for us.

### 8. Competent law court

For any controversy the competent Court will be the Bologna Court of Justice.





# STANZANI

Tools and equipment for body shops



